

SERIE

H

CILINDRI ISO 15552
ISO 15552 CYLINDERS



ARTEC[®]
PNEUMATIC COMPONENTS

CARATTERISTICHE TECNICHE - TECHNICAL CHARACTERISTICS

Pressione di esercizio <i>Working pressure</i>	1 ÷ 10 bar (doppio effetto - <i>double acting</i>)
Temperatura di esercizio <i>Working temperature</i>	0 ÷ +80°C (-20°C con aria secca - <i>with dry air</i>) 0 ÷ +150°C (con guarnizioni per alte temperature - <i>with high temperature seals</i>)
Versioni - Versions	doppio effetto - stelo passante - antirotazione - tandem <i>double acting - double rod - anti-rotation - tandem</i>
Alesaggi - Bores	∅ 32 - 40 - 50 - 63 - 80 - 100 - 125
Corse - Strokes	vedere tabelle corse standard - <i>see standard stroke tables</i>
Fluido - Fluid	aria compressa filtrata, non lubrificata - <i>compressed filtered, non lubricated air</i>

CARATTERISTICHE COSTRUTTIVE - CONSTRUCTIVE CHARACTERISTICS

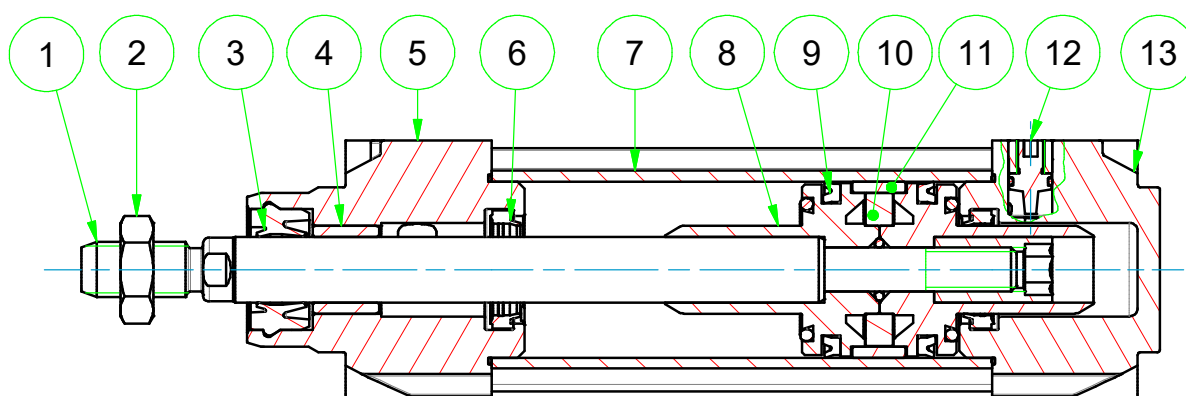
①	Stelo - Piston rod	acciaio C45 cromato - <i>C45 Chromed steel</i>
③ ⑥ ⑨	Guarnizioni - Seals	poliuretano - <i>polyurethane</i>
④	Boccola - Bush	bronzo sinterizzato - <i>sintered bronze</i>
⑤ ⑬	Testate - Covers	alluminio pressofuso verniciato - <i>painted die cast aluminium</i>
⑦	Tubo - Tube	alluminio anodizzato - <i>anodized aluminium</i>
⑩	Magnete - Magnet	plastoferrite - <i>rubber magnet</i>
⑪	Pattino di guida - Guide ring	PBT+PTFE
⑧	Pistone - Piston	alluminio pressofuso - <i>die cast aluminium</i>
⑫	Ammortizzo - Cushioning	acciaio nichelato - <i>nickel-plated steel</i>
	Viti - Screws	acciaio zincato - <i>zinc coated steel</i>
	O-ring	NBR



CHIAVE DI CODIFICA
KEY CODE
H D M 0 5 0 . 1 0 0 . G S . M

		ALESAGGIO - BORE (Ø) 032-040-050-063-080 100-125	CORSA - STROKE (mm) vedere tabelle corse std see std stroke tables			OPZIONE - OPTION EX ATEX II 2GD c T4
		VERSIONE - VERSION				OPZIONE - OPTION
Ø32-63	P	stelo passante double rod				UDM CI CICT montata (solo serie U) CICT mounted (serie U only)
	A	antirotazione anti-rotation				
		GUARNIZIONI - SEALS				OPZIONE - OPTION
		guarnizioni standard standard seals		GS		
		guarnizione stelo per alte temperature high temperature rod seal		VR		
		tutte le guarnizioni per alte temperature all seals for high temperature		VA		
		guarnizione stelo EU P5600 EU P5600 rod seal		PS		
		guarnizione stelo E8 E8 rod seal		ES		
		guarnizione stelo EW (raschiatore metallico) EW rod seal (metal scraper)		WS		
		VERSIONE - VERSION				OPZIONE - OPTION
		semplice effetto molla anteriore single acting front spring				W senza ammortizzo without cushioning
		semplice effetto molla posteriore single acting rear spring				WR senza ammortizzo posteriore without rear cushioning
		doppio effetto double acting				WF senza ammortizzo anteriore without front cushioning
		SERIE - SERIES				OPZIONE - OPTION
		H tubo profilato con cave per sensori tube with slots for sensors				X4 stelo in acciaio inox AISI 304 cromato chromed AISI 304 SS rod
		U tubo tondo con tiranti round tube with tie rods				X6 stelo in acciaio inox AISI 316 AISI 316 SS rod
						S viti inox SS screws
						B stelo prolungato per bloccastelo BH extended rod for BH rod lock
						B1 stelo prolungato con bloccastelo BH montato extended rod with BH rod lock mounted
				STELO - ROD		
				femmina female		
				maschio male		
				forato telescopico telescopic hollow rod		

 Cilindri tandem vedi pagina 109
 Tandem cylinders see page 109

ESECUZIONI A RICHIESTA - ON REQUEST

Filetti speciali (dado non fornito) - Special thread (without rod nut)

Stelo prolungato (WH) - Extended rod (WH)

Corse fuori standard - Special strokes

Corse fino a 2800 mm - Strokes up to 2800 mm

ATEX II 2GD c T4

FORZE TEORICHE DI TRAZIONE (P=6BAR)
THEORETICAL FORCES OF TRACTION (P=6bar)

		∅	032	040	050	063	080	100	125
HDM - UDM	SPINTA THRUST	[N]	483	754	1.178	1.870	3.016	4.712	7.363
	TRAZIONE TRACTION	[N]	415	633	990	1.682	2.721	4.418	6.881
HDMP - UDMP	SPINTA THRUST	[N]	415	633	990	1.682	2.721	4.418	6.881
	TRAZIONE TRACTION	[N]	415	633	990	1.682	2.721	4.418	6.881

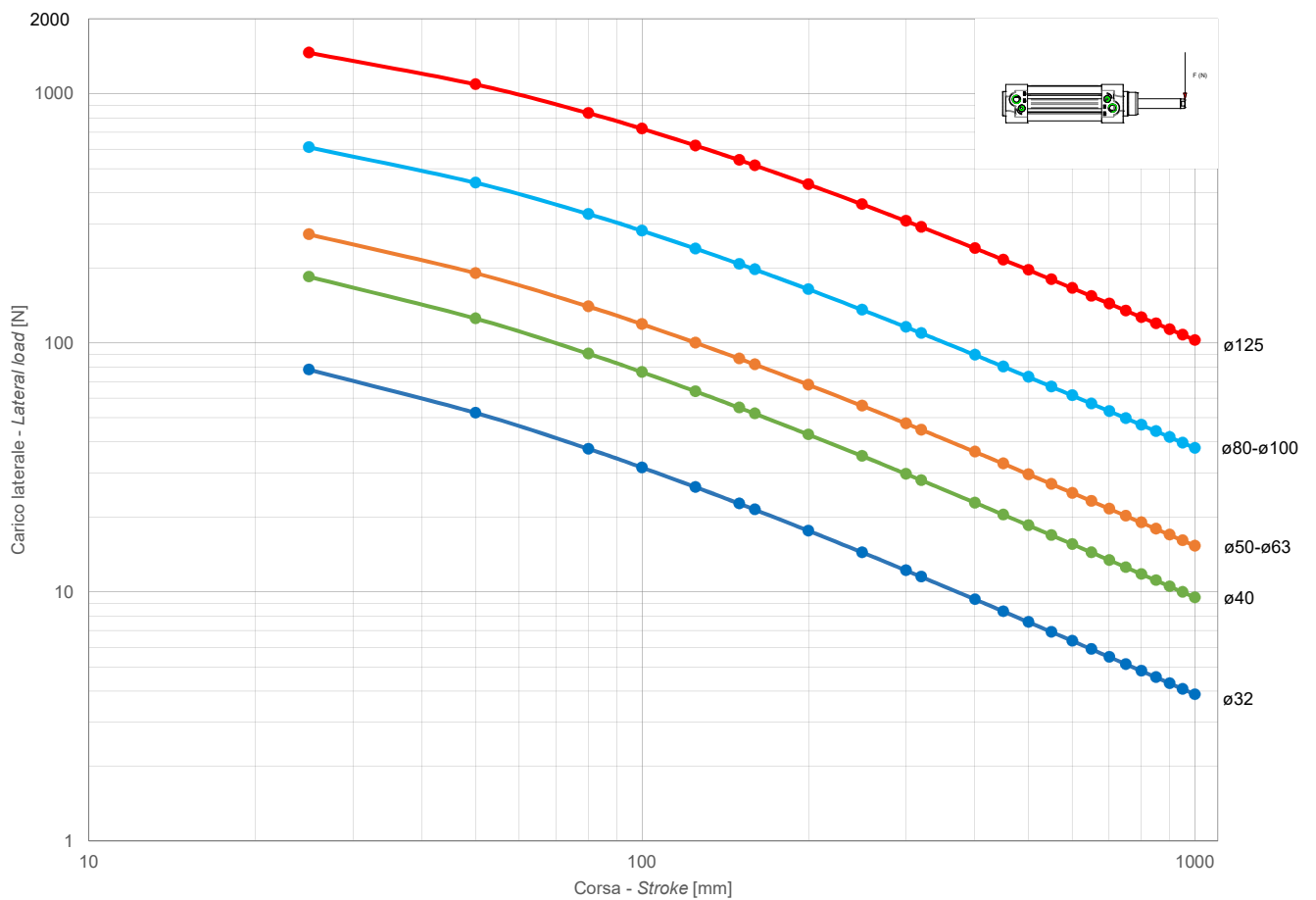
DIAGRAMMA TEORICO CARICO AMMISSIBILE
HDM
THEORETICAL ALLOWABLE LOAD

TUBO PROFILATO SERIE H

SERIE H PROFILE TUBE

SERIE

H

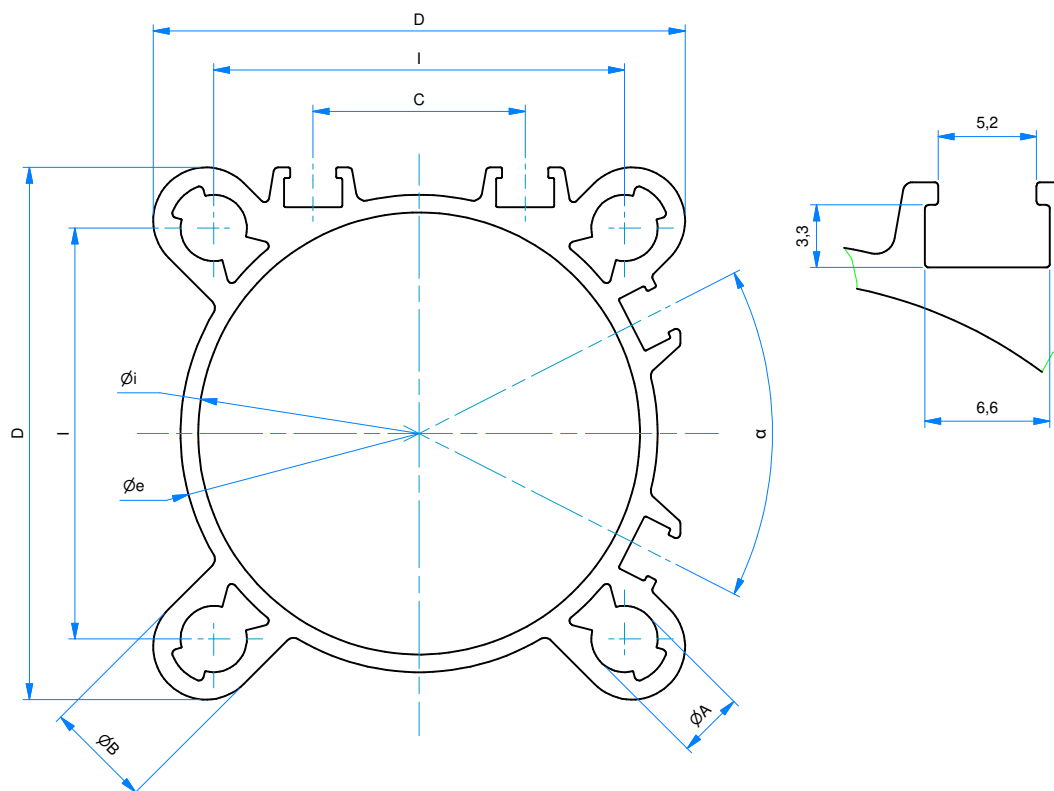

DIMENSIONI - DIMENSIONS

\varnothing_i	032	040	050	063	080	100	125
\varnothing_e	36	44	54	67,6	85,4	105,4	131
I	32,5	38	46,5	56,5	72	89	110
\varnothing_A	5,4	5,4	7,5	7,5	9,2	9,2	10,6
\varnothing_B	9	10	12	12	14	15	16,5
α°	46	51	54	61	65	68	70
C	13,8	19	24	35	45	56	64,2
D	44,3	51,4	60,2	70,4	86,6	105,5	131,5

SEMPLICE EFFETTO MAGNETICO - MOLLA ANTERIORE

SINGLE ACTING MAGNETIC - FRONT SPRING

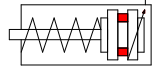

Note: lato molla cilindro non ammortizzato
spring side without cushioning

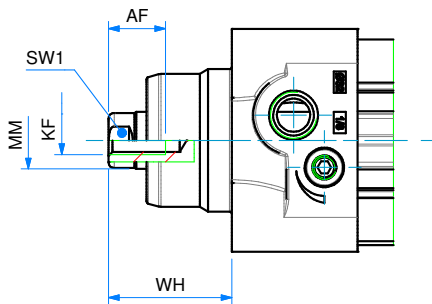
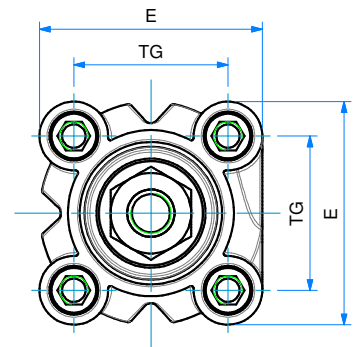
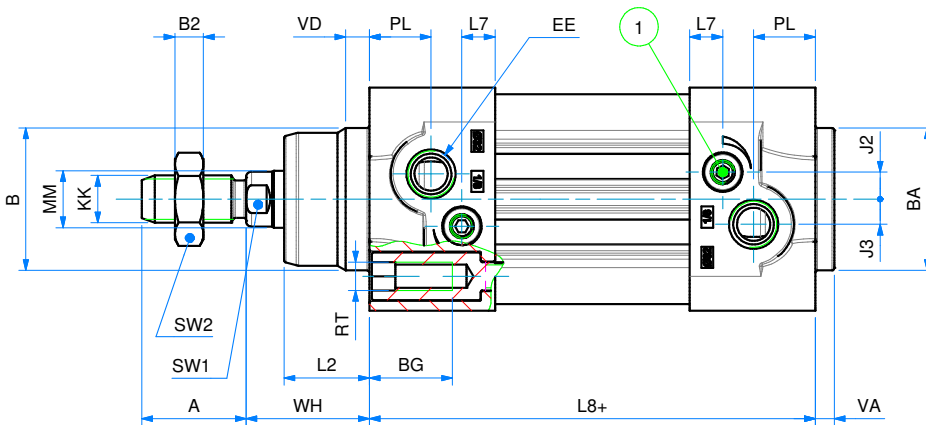

VERSIONE U - U VERSION

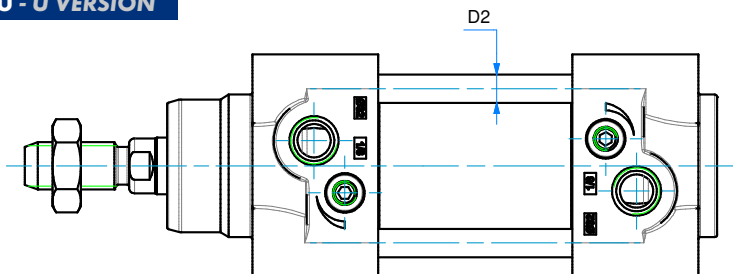

① Vite regolazione ammortizzo - Cushioning adjustment screw

SEMPLICE EFFETTO MAGNETICO - MOLLA ANTERIORE
SINGLE ACTING MAGNETIC - FRONT SPRING

SERIE

U
DIMENSIONI - DIMENSIONS

Ø	032	040	050	063	080	100	125
A	22	24	32	32	40	40	54
AF	12	12	16	16	20	20	32
Ø B	30	35	40	45	45	55	60
Ø BA	30	35	40	45	45	55	60
B2	6	7	8	8	9	9	12
BG	16	16	16	16	17	17	20
D2	6	6	8	8	10	10	12
E	47	54,5	65	75	93	110	134
EE	G1/8"	G1/4"	G1/4"	G3/8"	G3/8"	G1/2"	G1/2"
J2	5,7	7,3	7	8	8	12	10
J3	5,3	5	6	7,5	7	7	7
KF	M6	M8	M8	M10	M10	M12	M16
KK	M10x1,25	M12x1,25	M16x1,5	M16x1,5	M20x1,5	M20x1,5	M27x2
L2	18	22	25,5	26	32	38	46
L7	7	9,2	9	8	10,5	10	11
L8+	94**	105**	106**	121**	128**	138**	160**
Ø MM	12	16	20	20	25	25	32
PL	13	14	14	16	16	18	18
RT	M6	M6	M8	M8	M10	M10	M12
SW 1	10	13	17	17	22	22	27
SW 2	17	19	24	24	30	30	41
TG	32,5	38	46,5	56,5	72	89	110
VA	4	4	4	4	4	4	6
VD	5	5	6	6	7	7	10
WH	26	30	37	37	46	51	65
*	20	22	25	25	35	35	35

+ = lunghezza corsa - stroke length

* = lunghezza ammortizzo - cushioning length

** per corse - for strokes 100 - 125 - 150 - 160:

HSM 032 - 040 aggiungere - add +40 mm

HSM 050 - 063 aggiungere - add +45 mm

HSM 080 - 100 aggiungere - add +60 mm

HSM 125 aggiungere - add +65 mm

Note: dado stelo compreso nella fornitura

Note: rod nut included in the supply

Note: lato molla cilindro non ammortizzato - spring side without cushioning

Ø CORSE STANDARD - STANDARD STROKES
032 25 - 50 - 80 - 100 - 125 - 150 - 160

040 25 - 50 - 80 - 100 - 125 - 150 - 160

050 25 - 50 - 80 - 100 - 125 - 150 - 160

063 25 - 50 - 80 - 100 - 125 - 150 - 160

080 25 - 50 - 80 - 100 - 125 - 150 - 160

100 25 - 50 - 80 - 100 - 125 - 150 - 160

125 25 - 50 - 80 - 100 - 125 - 150 - 160

SERIE **H** **SEMPLICE EFFETTO MAGNETICO - MOLLA POSTERIORE**

SINGLE ACTING MAGNETIC - REAR SPRING

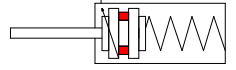

Note: lato molla cilindro non ammortizzato
spring side without cushioning

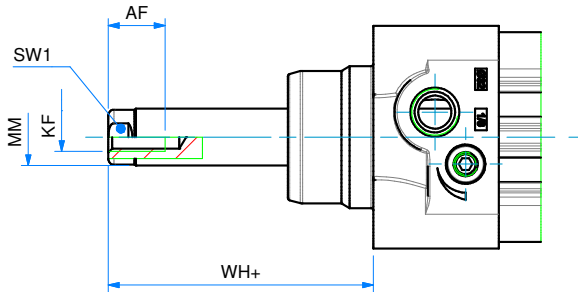
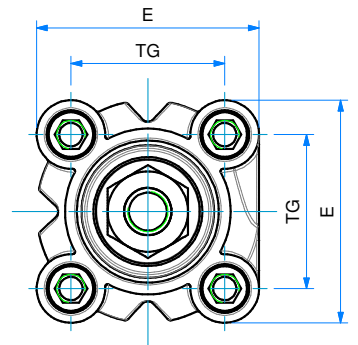
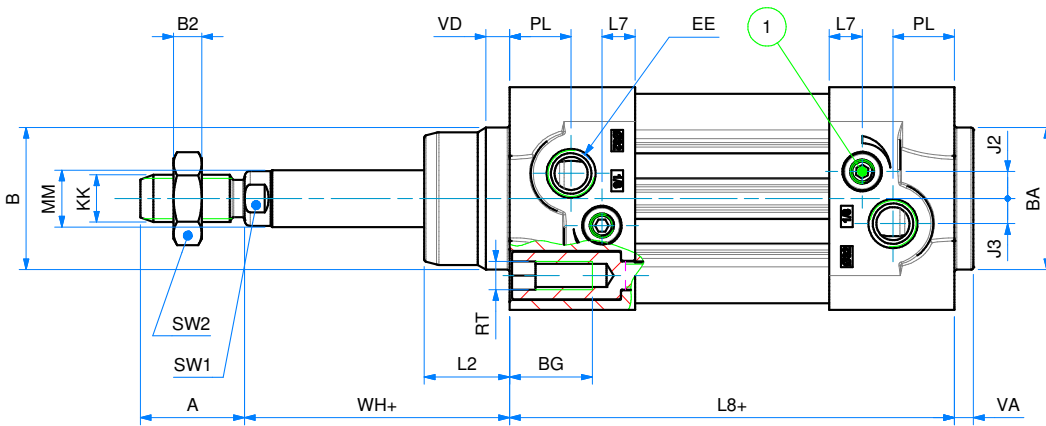

VERSIONE U - U VERSION

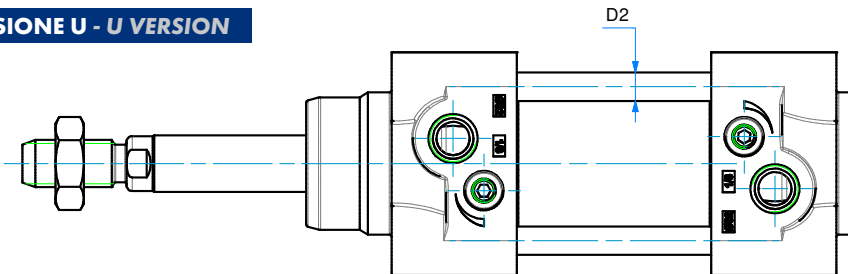

① Vite regolazione ammortizzo - Cushioning adjustment screw

SEMPLICE EFFETTO MAGNETICO - MOLLA POSTERIORE
SINGLE ACTING MAGNETIC - REAR SPRING

DIMENSIONI - DIMENSIONS							
Ø	032	040	050	063	080	100	125
A	22	24	32	32	40	40	54
AF	12	12	16	16	20	20	32
Ø B	30	35	40	45	45	55	60
Ø BA	30	35	40	45	45	55	60
B2	6	7	8	8	9	9	12
BG	16	16	16	16	17	17	20
D2	6	6	8	8	10	10	12
E	47	54,5	65	75	93	110	134
EE	G1/8"	G1/4"	G1/4"	G3/8"	G3/8"	G1/2"	G1/2"
J2	5,7	7,3	7	8	8	12	10
J3	5,3	5	6	7,5	7	7	7
KF	M6	M8	M8	M10	M10	M12	M16
KK	M10x1,25	M12x1,25	M16x1,5	M16x1,5	M20x1,5	M20x1,5	M27x2
L2	18	22	25,5	26	32	38	46
L7	7	9,2	9	8	10,5	10	11
L8+	94**	105**	106**	121**	128**	138**	160**
Ø MM	12	16	20	20	25	25	32
PL	13	14	14	16	16	18	18
RT	M6	M6	M8	M8	M10	M10	M12
SW 1	10	13	17	17	22	22	27
SW 2	17	19	24	24	30	30	41
TG	32,5	38	46,5	56,5	72	89	110
VA	4	4	4	4	4	4	6
VD	5	5	6	6	7	7	10
WH	26	30	37	37	46	51	65
WH+	26	30	37	37	46	51	65
*	20	22	25	25	35	35	35

 + = lunghezza corsa - *stroke length*

 * = lunghezza ammortizzo - *cushioning length*

 ** per corse - *for strokes* 100 - 125 - 150 - 160:

 HSM 032 - 040 aggiungere - *add* +40 mm

 HSM 050 - 063 aggiungere - *add* +45 mm

 HSM 080 - 100 aggiungere - *add* +60 mm

 HSM 125 aggiungere - *add* +65 mm

 Note: lato molla cilindro non ammortizzato - *spring side without cushioning*

Note: dado stelo compreso nella fornitura

Note: rod nut included in the supply

Ø	CORSE STANDARD - STANDARD STROKES
032	25 - 50 - 80 - 100 - 125 - 150 - 160
040	25 - 50 - 80 - 100 - 125 - 150 - 160
050	25 - 50 - 80 - 100 - 125 - 150 - 160
063	25 - 50 - 80 - 100 - 125 - 150 - 160
080	25 - 50 - 80 - 100 - 125 - 150 - 160
100	25 - 50 - 80 - 100 - 125 - 150 - 160
125	25 - 50 - 80 - 100 - 125 - 150 - 160

DOPPIO EFFETTO MAGNETICO AMMORTIZZATO

DOUBLE ACTING MAGNETIC CUSHIONED

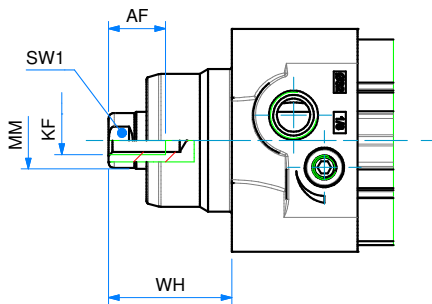
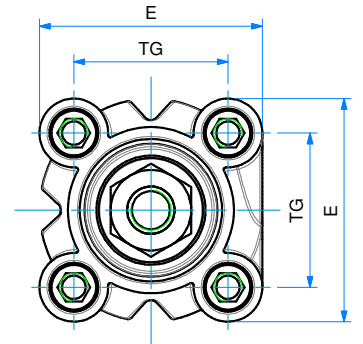
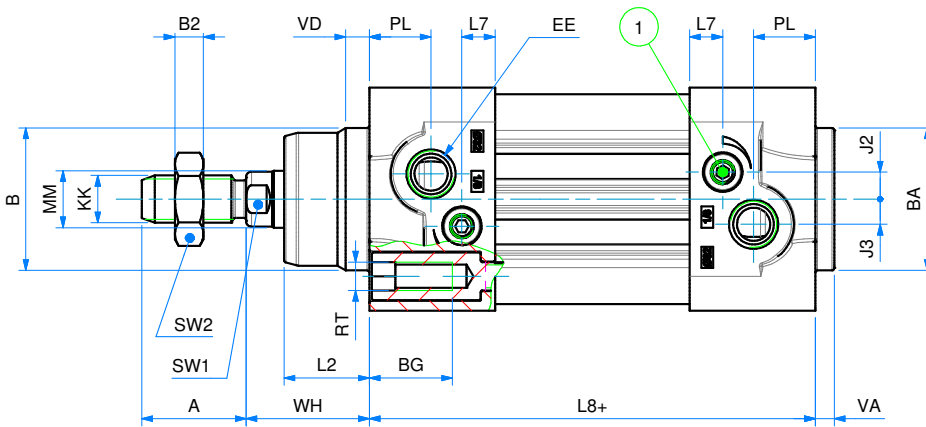
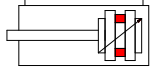

VERSIONE U - U VERSION

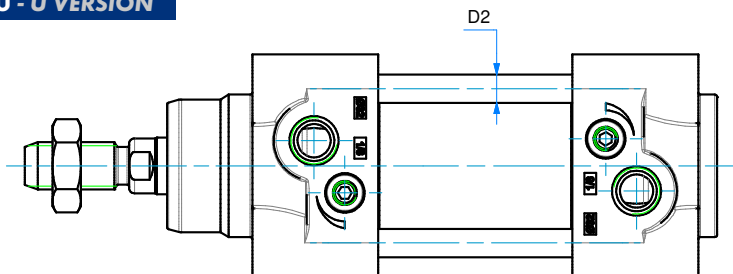

① Vite regolazione ammortizzo - Cushioning adjustment screw

DOPPIO EFFETTO MAGNETICO AMMORTIZZATO
DOUBLE ACTING MAGNETIC CUSHIONED

DIMENSIONI - DIMENSIONS							
Ø	032	040	050	063	080	100	125
A	22	24	32	32	40	40	54
AF	12	12	16	16	20	20	32
Ø B	30	35	40	45	45	55	60
Ø BA	30	35	40	45	45	55	60
B2	6	7	8	8	9	9	12
BG	16	16	16	16	17	17	20
D2	6	6	8	8	10	10	12
E	47	54,5	65	75	93	110	134
EE	G1/8"	G1/4"	G1/4"	G3/8"	G3/8"	G1/2"	G1/2"
J2	5,7	7,3	7	8	8	12	10
J3	5,3	5	6	7,5	7	7	7
KF	M6	M8	M8	M10	M10	M12	M16
KK	M10x1,25	M12x1,25	M16x1,5	M16x1,5	M20x1,5	M20x1,5	M27x2
L2	18	22	25,5	26	32	38	46
L7	7	9,2	9	8	10,5	10	11
L8+	94	105	106	121	128	138	160
Ø MM	12	16	20	20	25	25	32
PL	13	14	14	16	16	18	18
RT	M6	M6	M8	M8	M10	M10	M12
SW 1	10	13	17	17	22	22	27
SW 2	17	19	24	24	30	30	41
TG	32,5	38	46,5	56,5	72	89	110
VA	4	4	4	4	4	4	6
VD	5	5	6	6	7	7	10
WH	26	30	37	37	46	51	65
*	20	22	25	25	35	35	35

+ = lunghezza corsa - stroke length

* = lunghezza ammortizzo - cushioning length

Note: dado stelo compreso nella fornitura

Note: rod nut included in the supply

OPZIONE B - OPTION B							
Ø	032	040	050	063	080	100	125
WH	86	100	127	127	156	161	205

Ø CORSE STANDARD - STANDARD STROKES	
032	25 - 50 - 80 - 100 - 125 - 150 - 160 - 200 - 250 - 300 - 320 - 400 - 450 - 500 - 550 - 600 - 650 - 700 - 750 - 800 - 850 - 900 - 950 - 1000
040	25 - 50 - 80 - 100 - 125 - 150 - 160 - 200 - 250 - 300 - 320 - 400 - 450 - 500 - 550 - 600 - 650 - 700 - 750 - 800 - 850 - 900 - 950 - 1000
050	25 - 50 - 80 - 100 - 125 - 150 - 160 - 200 - 250 - 300 - 320 - 400 - 450 - 500 - 550 - 600 - 650 - 700 - 750 - 800 - 850 - 900 - 950 - 1000
063	25 - 50 - 80 - 100 - 125 - 150 - 160 - 200 - 250 - 300 - 320 - 400 - 450 - 500 - 550 - 600 - 650 - 700 - 750 - 800 - 850 - 900 - 950 - 1000
080	25 - 50 - 80 - 100 - 125 - 150 - 160 - 200 - 250 - 300 - 320 - 400 - 450 - 500 - 550 - 600 - 650 - 700 - 750 - 800 - 850 - 900 - 950 - 1000
100	25 - 50 - 80 - 100 - 125 - 150 - 160 - 200 - 250 - 300 - 320 - 400 - 450 - 500 - 550 - 600 - 650 - 700 - 750 - 800 - 850 - 900 - 950 - 1000
125	25 - 50 - 80 - 100 - 125 - 150 - 160 - 200 - 250 - 300 - 320 - 400 - 450 - 500 - 550 - 600 - 650 - 700 - 750 - 800 - 850 - 900 - 950 - 1000

DOPPIO EFFETTO MAGNETICO STELO PASSANTE AMMORTIZZATO

DOUBLE ACTING MAGNETIC CUSHIONED WITH DOUBLE ROD

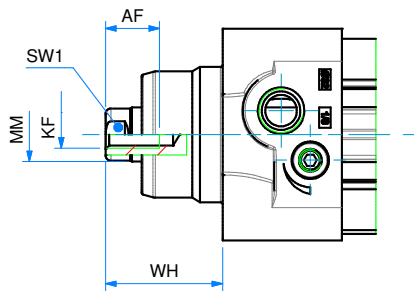
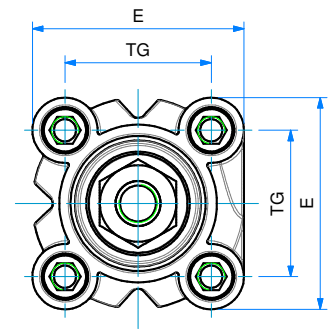
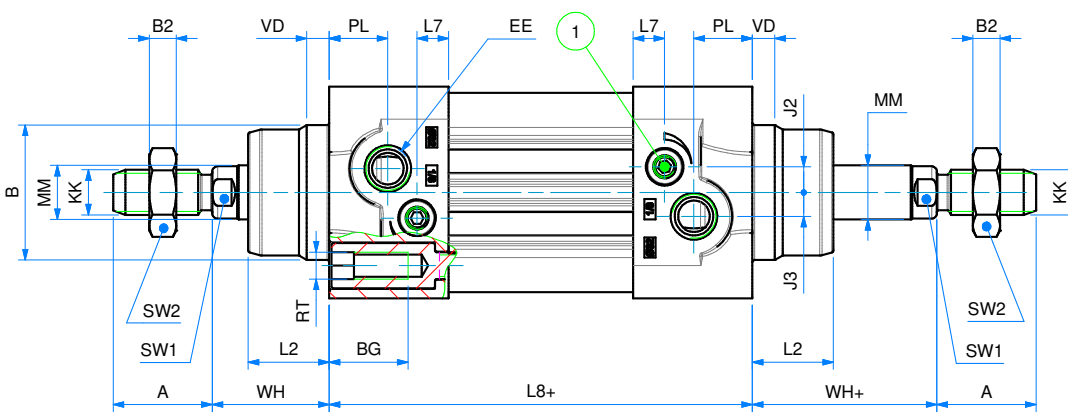
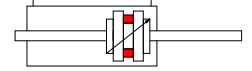

VERSIONE U - U VERSION

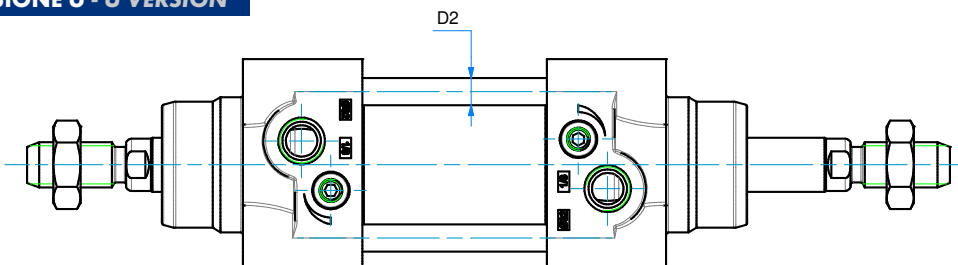

① Vite regolazione ammortizzo - Cushioning adjustment screw

DOPPIO EFFETTO MAGNETICO STELO PASSANTE AMMORTIZZATO
DOUBLE ACTING MAGNETIC CUSHIONED WITH DOUBLE ROD

DIMENSIONI - DIMENSIONS							
Ø	032	040	050	063	080	100	125
A	22	24	32	32	40	40	54
AF	12	12	16	16	20	20	32
Ø B	30	35	40	45	45	55	60
B2	6	7	8	8	9	9	12
BG	16	16	16	16	17	17	20
D2	6	6	8	8	10	10	12
E	47	54,5	65	75	93	110	134
EE	G1/8"	G1/4"	G1/4"	G3/8"	G3/8"	G1/2"	G1/2"
J2	5,7	7,3	7	8	8	12	10
J3	5,3	5	6	7,5	7	7	7
KF	M6	M8	M8	M10	M10	M12	M16
KK	M10x1,25	M12x1,25	M16x1,5	M16x1,5	M20x1,5	M20x1,5	M27x2
L2	18	22	25,5	26	32	38	46
L7	7	9,2	9	8	10,5	10	11
L8+	94	105	106	121	128	138	160
Ø MM	12	16	20	20	25	25	32
PL	13	14	14	16	16	18	18
RT	M6	M6	M8	M8	M10	M10	M12
SW 1	10	13	17	17	22	22	27
SW 2	17	19	24	24	30	30	41
TG	32,5	38	46,5	56,5	72	89	110
VD	5	5	6	6	7	7	10
WH	26	30	37	37	46	51	65
WH+	26	30	37	37	46	51	65
*	20	22	25	25	35	35	35

+ = lunghezza corsa - stroke length

* = lunghezza ammortizzo - cushioning length

Note: dado stelo compreso nella fornitura

Note: rod nut included in the supply

OPZIONE B - OPTION B							
Ø	032	040	050	063	080	100	125
WH	86	100	127	127	156	161	205

Ø CORSE STANDARD - STANDARD STROKES	
032	25 - 50 - 80 - 100 - 125 - 150 - 160 - 200 - 250 - 300 - 320 - 400 - 450 - 500 - 550 - 600 - 650 - 700 - 750 - 800 - 850 - 900 - 950 - 1000
040	25 - 50 - 80 - 100 - 125 - 150 - 160 - 200 - 250 - 300 - 320 - 400 - 450 - 500 - 550 - 600 - 650 - 700 - 750 - 800 - 850 - 900 - 950 - 1000
050	25 - 50 - 80 - 100 - 125 - 150 - 160 - 200 - 250 - 300 - 320 - 400 - 450 - 500 - 550 - 600 - 650 - 700 - 750 - 800 - 850 - 900 - 950 - 1000
063	25 - 50 - 80 - 100 - 125 - 150 - 160 - 200 - 250 - 300 - 320 - 400 - 450 - 500 - 550 - 600 - 650 - 700 - 750 - 800 - 850 - 900 - 950 - 1000
080	25 - 50 - 80 - 100 - 125 - 150 - 160 - 200 - 250 - 300 - 320 - 400 - 450 - 500 - 550 - 600 - 650 - 700 - 750 - 800 - 850 - 900 - 950 - 1000
100	25 - 50 - 80 - 100 - 125 - 150 - 160 - 200 - 250 - 300 - 320 - 400 - 450 - 500 - 550 - 600 - 650 - 700 - 750 - 800 - 850 - 900 - 950 - 1000
125	25 - 50 - 80 - 100 - 125 - 150 - 160 - 200 - 250 - 300 - 320 - 400 - 450 - 500 - 550 - 600 - 650 - 700 - 750 - 800 - 850 - 900 - 950 - 1000

DOPPIO EFFETTO MAGNETICO AMMORTIZZATO ANTIROTAZIONE (INTERNA)

DOUBLE ACTING MAGNETIC CUSHIONED ANTI-ROTATION (INTERNAL)



Il sistema antirotazione è interno. Le dimensioni esterne sono standard come per il cilindro HDM ISO 15552.

The anti-rotation system is internal. The external dimensions are standard as HDM ISO 15552 cylinder.

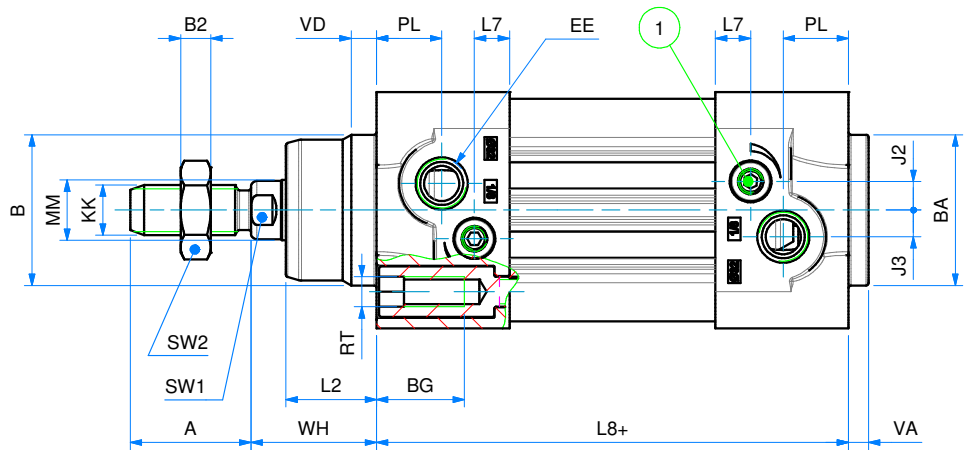
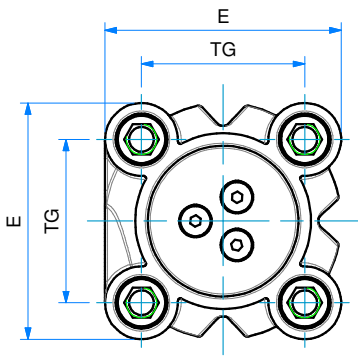

① Vite regolazione ammortizzo - Cushioning adjustment screw

DOPPIO EFFETTO MAGNETICO AMMORTIZZATO
DOUBLE ACTING MAGNETIC CUSHIONED

DIMENSIONI - DIMENSIONS				
Ø	032	040	050	063
A	22	24	32	32
AF	12	12	16	16
Ø B	30	35	40	45
Ø BA	30	35	40	45
B2	6	7	8	8
BG	16	16	16	16
E	47	54,5	65	75
EE	G1/8"	G1/4"	G1/4"	G3/8"
J2	5,7	7,3	7	8
J3	5,3	5	6	7,5
KK	M10x1,25	M12x1,25	M16x1,5	M16x1,5
L2	18	22	25,5	26
L7	7	9,2	9	8
L8+	94	105	106	121
Ø MM	12	16	20	20
PL	13	14	14	16
RT	M6	M6	M8	M8
SW 1	10	13	17	17
SW 2	17	19	24	24
TG	32,5	38	46,5	56,5
VA	4	4	4	4
VD	5	5	6	6
WH	26	30	37	37
*	20	22	25	25

+ = lunghezza corsa - stroke length

* = lunghezza ammortizzo - cushioning length

Note: dado stelo compreso nella fornitura

Note: rod nut included in the supply

VERSIONE U - U VERSION				
Ø	032	040	050	063
Ø tiranti Ø tie rods	6	6	8	8

OPZIONE B - OPTION B				
Ø	032	040	050	063
WH	86	100	127	127

Ø	CORSE STANDARD - STANDARD STROKES
032	25 - 50 - 80 - 100 - 125 - 150 - 160 - 200 - 250 - 300 - 320 - 400 - 450 - 500 - 550 - 600 - 650 - 700 - 750 - 800 - 850 - 900 - 950 - 1000
040	25 - 50 - 80 - 100 - 125 - 150 - 160 - 200 - 250 - 300 - 320 - 400 - 450 - 500 - 550 - 600 - 650 - 700 - 750 - 800 - 850 - 900 - 950 - 1000
050	25 - 50 - 80 - 100 - 125 - 150 - 160 - 200 - 250 - 300 - 320 - 400 - 450 - 500 - 550 - 600 - 650 - 700 - 750 - 800 - 850 - 900 - 950 - 1000
063	25 - 50 - 80 - 100 - 125 - 150 - 160 - 200 - 250 - 300 - 320 - 400 - 450 - 500 - 550 - 600 - 650 - 700 - 750 - 800 - 850 - 900 - 950 - 1000

Il sistema antirotazione è interno. Le dimensioni esterne sono standard come per il cilindro HDM ISO 15552.

The anti-rotation system is internal. The external dimensions are standard as HDM ISO 15552 cylinder.

DOPPIO EFFETTO MAGNETICO CON STELO FORATO

DOUBLE ACTING MAGNETIC WITH HOLLOW ROD

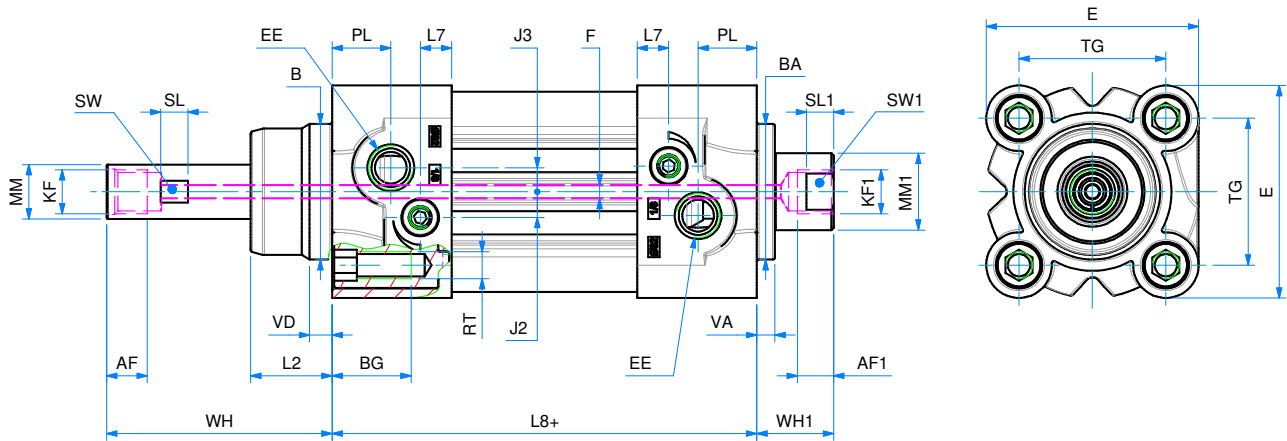
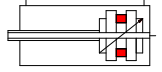
DIMENSIONI - DIMENSIONS

	032	040	050	063
AF	7,5	10	12	12
AF1	7,5	9	12	12
ø B	30	35	40	45
ø BA	30	35	40	45
BG	16	16	16	16
E	47	54,5	65	75
EE	G1/8"	G1/4"	G1/4"	G3/8"
F	3	5	7	7
J3	5,3	5	6	7,5
KF	G1/8"	G1/4"	G3/8"	G3/8"
KF1	G1/8"	G1/4"	G1/4"	G1/4"
L2	18	22	25,5	26
L8+	94	105	106	121
ø MM	12	16	20	20
ø MM1	17	20	21	21
PL	13	14	14	16
RT	M6	M6	M8	M8
SL	6	7	8	8
SL1	6	6	6	6
SW	11	14	18	18
SW1	15	18	18	18
TG	32,5	38	46,5	56,5
VA	4	4	4	4
VD	5	5	6	6
WH	50	40	41	41
WH1	17,5	19	19	19

ø CORSE STANDARD - STANDARD STROKES

032	50 - 100 - 150 - 200 - 250 - 300 - 350
040	50 - 100 - 150 - 200 - 250 - 300 - 350
050	50 - 100 - 150 - 200 - 250 - 300 - 350
063	50 - 100 - 150 - 200 - 250 - 300 - 350

+ = lunghezza corsa - stroke length

CILINDRI TANDEM - TANDEM CYLINDERS

SERIE

H

CHIAVE DI CODIFICA - KEY CODE

H T 2 M 1 0 0 . 0 5 0 . G S . M

VERSIONE - VERSION

- T2** tandem doppia spinta
double thrust tandem
- T3** tandem tripla spinta
3 x force
- T4** tandem quadrupla spinta
4 x force

OPZIONE - OPTION

EX ATEX II 2GD cT4

OPZIONE - OPTION

X4 stelo inox AISI 304 cromato
chromed AISI 304 SS rod

H P M 1 0 0 . 0 5 0 . 0 8 0 . G S . M

**ALESAGGIO
BORE (Ø)**

032-040-050-063-080
100-125

**I° CORSA (mm)
I° STROKE (mm)**

vedere tabelle corse std
see std stroke tables

**II° CORSA (mm)
II° STROKE (mm)**

vedere tabelle corse std
see std stroke tables

OPZIONE - OPTION

X4 stelo inox AISI 304 cromato
chromed AISI 304 SS rod

VERSIONE - VERSION

- M** magnetico - *magnetic*
- non magnetico - *non-magnetic*

VERSIONE - VERSION

- P** tandem più posizioni
multi-position tandem
- C** tandem contrapposti posteriori
rear opposed tandem
- F** tandem contrapposti anteriori
front opposed tandem

GUARNIZIONI - SEALS

guarnizioni standard
standard seals **GS**

guarnizione stelo
per alte temperature
high temperature rod seal **VR**

tutte le guarnizioni per
alte temperature
all seals for high temperature **VA**

guarnizione stelo EU P5600
EU P5600 rod seal **PS**

guarnizione stelo E8
E8 rod seal **ES**

guarnizione stelo EW
(raschiatore metallico)
EW rod seal (metal scraper) **WS**

STELO - ROD

F femmina
Female

M maschio
male

SERIE - SERIES

H tubo profilato con cave per sensori
tube with slots for sensors

U tubo tondo con tiranti
round tube with tie rods

DOPPIA SPINTA - DOUBLE THRUST

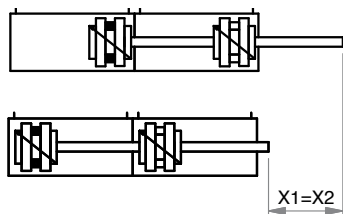

PIÙ POSIZIONI - MULTI-POSITION

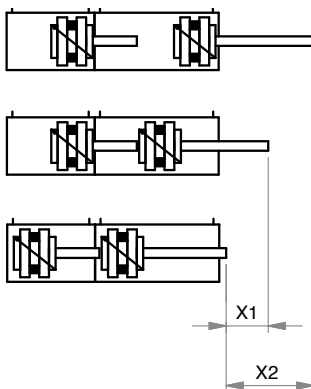

CONTRAPPOSTI POSTERIORI - REAR OPPOSED

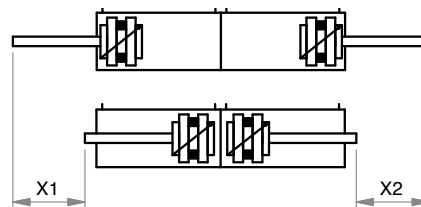

CONTRAPPOSTI ANTERIORI - FRONT OPPOSED

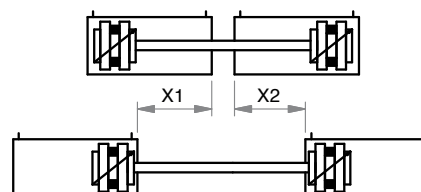

3ED

X1= 1° corsa - 1° stroke
X2= 2° corsa - 2° stroke

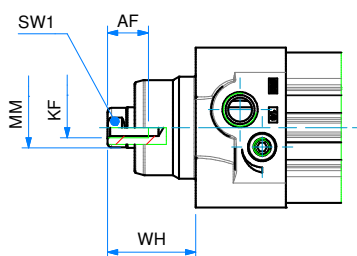
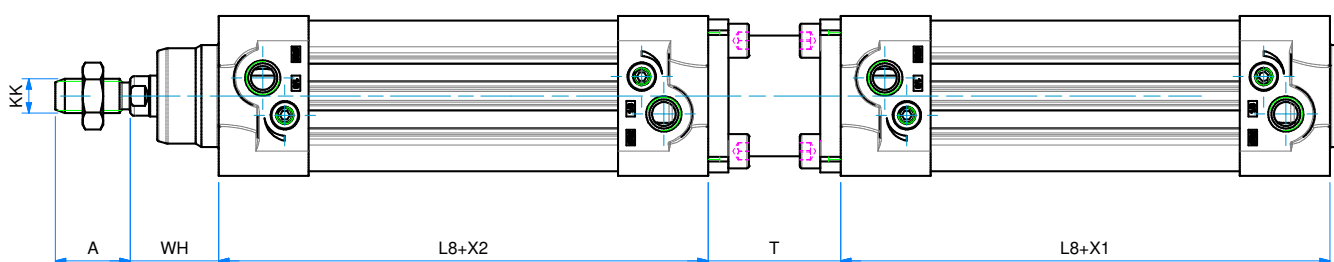
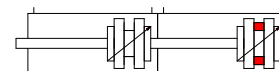
SERIE H TANDEM DOPPIA SPINTA D.E.M. AMMORTIZZATO
DOUBLE THRUST TANDEM D.A.M. CUSHIONED

Note: dado stelo compreso nella fornitura
 Note: rod nut included in the supply

DIMENSIONI - DIMENSIONS

∅	032	040	050	063	080	100	125
A	22	24	32	32	40	40	54
AF	12	12	16	16	20	20	32
KF	M6	M8	M8	M10	M10	M12	M16
KK	M10x1,25	M12x1,25	M16x1,5	M16x1,5	M20x1,5	M20x1,5	M27x2
L8	94	105	106	121	128	138	160
∅ MM	12	16	20	20	25	25	32
SW 1	10	13	17	17	22	22	27
T	39	45	52	53	65	77	93
WH	26	30	37	37	46	51	65
X1	I° CORSA - I° STROKE						
X2	II° CORSA - II° STROKE						
*	20	22	25	25	35	35	35

* = lunghezza ammortizzo - cushioning length

OPZIONE B - OPTION B

∅	032	040	050	063	080	100	125
WH	86	100	127	127	156	161	205

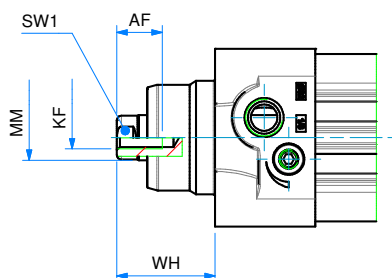
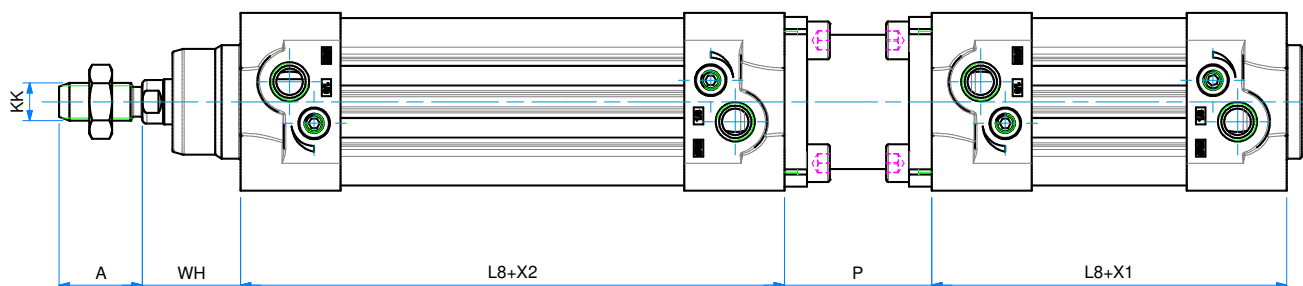
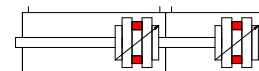
TANDEM PIÙ POSIZIONI D.E.M. AMMORTIZZATO
MULTI-POSITION TANDEM D.A.M. CUSHIONED

Note: dado stelo compreso nella fornitura
 Note: rod nut included in the supply

DIMENSIONI - DIMENSIONS

Ø	032	040	050	063	080	100	125
A	22	24	32	32	40	40	54
AF	12	12	16	16	20	20	32
KF	M6	M8	M8	M10	M10	M12	M16
KK	M10x1,25	M12x1,25	M16x1,5	M16x1,5	M20x1,5	M20x1,5	M27x2
L8	94	105	106	121	128	138	160
Ø MM	12	16	20	20	25	25	32
SW 1	10	13	17	17	22	22	27
P	39	45	52	53	65	77	93
WH	26	30	37	37	46	51	65
X1	I° CORSA - I° STROKE						
X2	II° CORSA - II° STROKE						
*	20	22	25	25	35	35	35

* = lunghezza ammortizzo - cushioning length

OPZIONE B - OPTION B

Ø	032	040	050	063	080	100	125
WH	86	100	127	127	156	161	205

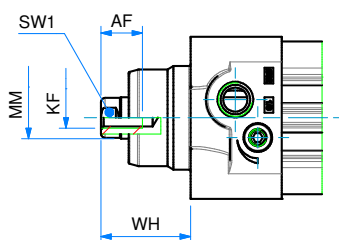
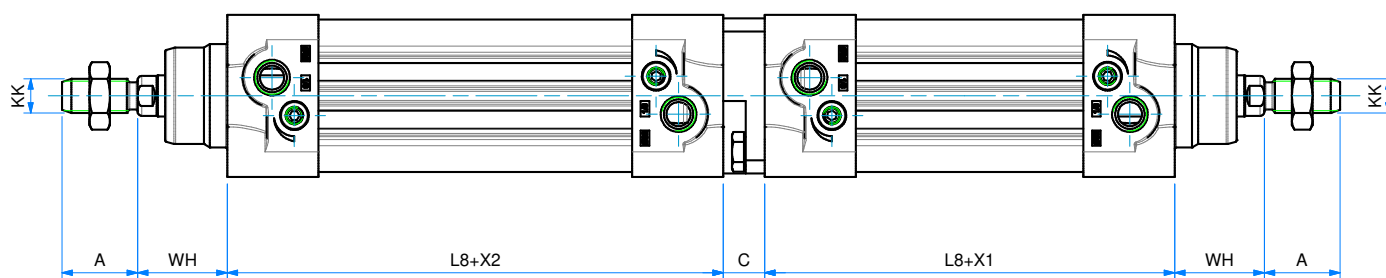
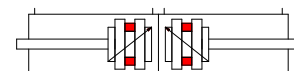
TANDEM CONTRAPPOSTI POSTERIORI D.E.M. AMMORTIZZATO
REAR OPPOSED TANDEM D.A.M. CUSHIONED

Note: dado stelo compreso nella fornitura
 Note: rod nut included in the supply

DIMENSIONI - DIMENSIONS

∅	032	040	050	063	080	100	125
A	22	24	32	32	40	40	54
AF	12	12	16	16	20	20	32
C	12	12	16	16	20	20	30
KF	M6	M8	M8	M10	M10	M12	M16
KK	M10x1,25	M12x1,25	M16x1,5	M16x1,5	M20x1,5	M20x1,5	M27x2
L8	94	105	106	121	128	138	160
∅ MM	12	16	20	20	25	25	32
SW 1	10	13	17	17	22	22	27
WH	26	30	37	37	46	51	65
X1	I° CORSA - I° STROKE						
X2	II° CORSA - II° STROKE						
*	20	22	25	25	35	35	35

* = lunghezza ammortizzo - cushioning length

OPZIONE B - OPTION B

∅	032	040	050	063	080	100	125
WH	86	100	127	127	156	161	205

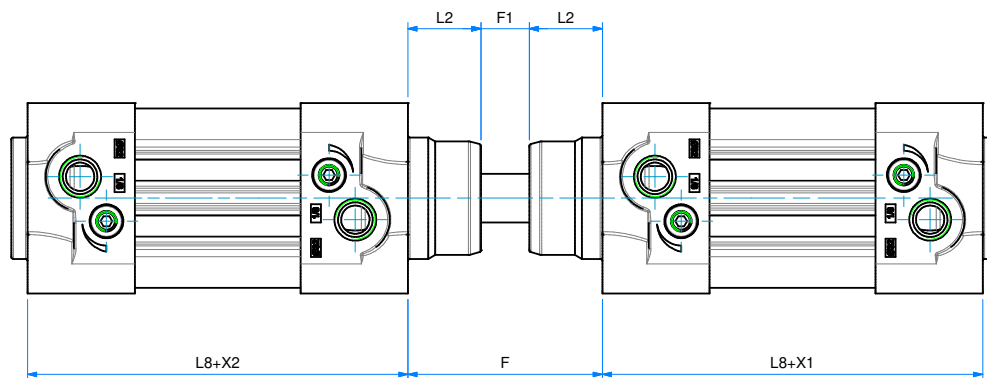
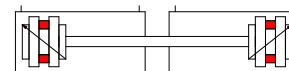
TANDEM CONTRAPPOSTI ANTERIORI D.E.M. AMMORTIZZATO
FRONT OPPOSED TANDEM D.A.M. CUSHIONED

DIMENSIONI - DIMENSIONS

Ø	032	040	050	063	080	100	125
F	48	59	69	70	86	98	120
F1	12	15	18	18	22	22	28
L2	18	22	25,5	26	32	38	46
L8	94	105	106	121	128	138	160
X1	I° CORSA - I° STROKE						
X2	II° CORSA - II° STROKE						
*	20	22	25	25	35	35	35

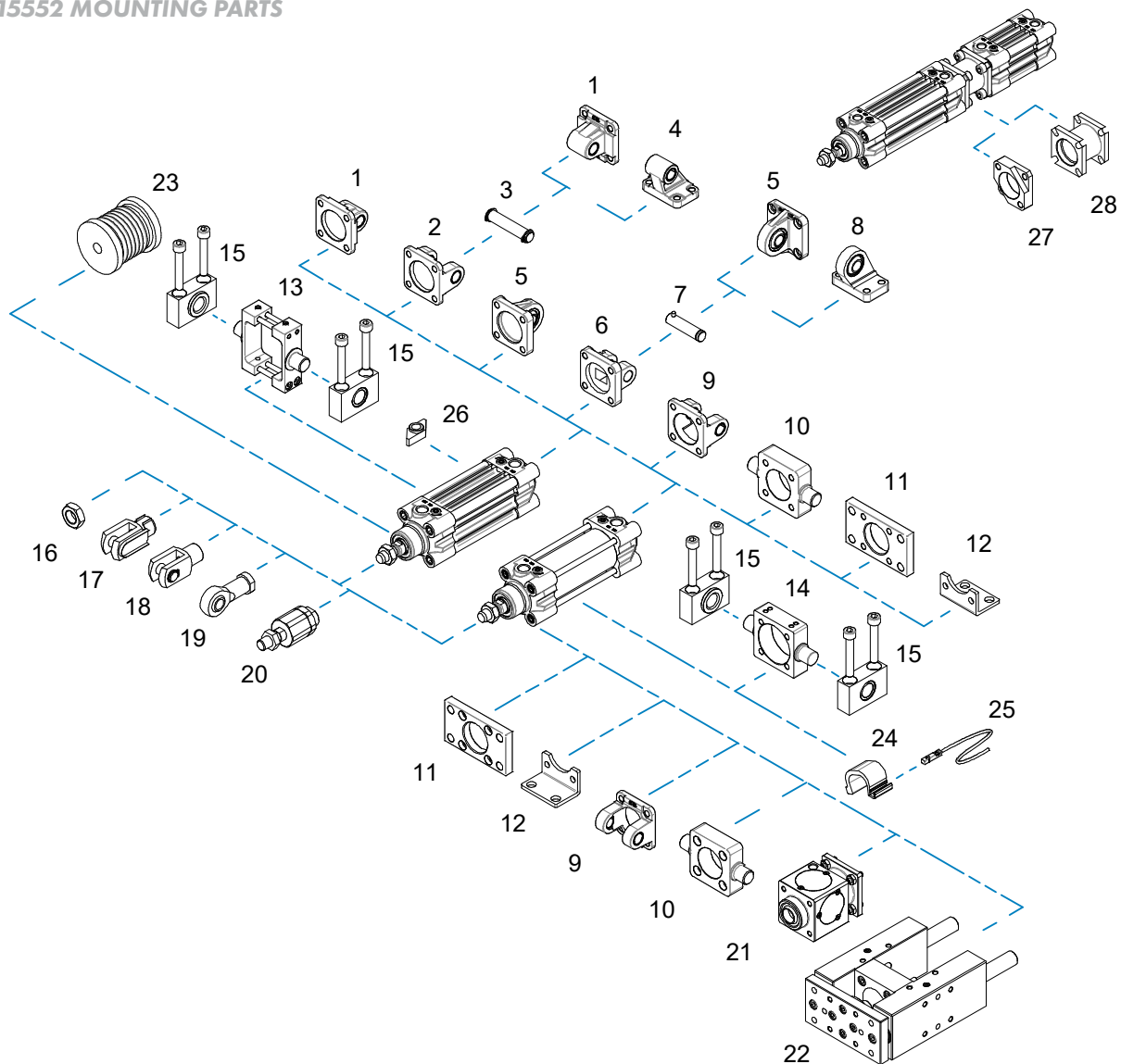
* = lunghezza ammortizzo - cushioning length

ACCESSORI DI FISSAGGIO ISO 15552
ISO 15552 MOUNTING PARTS

POS.	CODE	DESCRIZIONE-DESCRIPTION
1	CMI---	cerniera maschio iso - iso male hinge
2	CFI---	cerniera femmina iso - iso female hinge
3	PCF---	perno per cerniera - pin for hinge
4	ASI---	articolazione a squadra iso - iso square hinge
5	CMSI---	cerniera maschio snodata iso iso male hinge with ball joint
6	CFSI---	cerniera femmina stretta iso - iso narrow female hinge
7	PCFS---	perno per cerniera stretta - pin for narrow hinge
8	ASSI---	articolazione a squadra snodata iso square hinge with ball joint
9	CFI---F	cerniera femmina forata iso - hollow iso female hinge
10	CIA---	cerniera anteriore-posteriore lamata front-rear hinge
11	FI---	flangia iso - iso flange
12	PBI---	pieдино basso iso - iso foot mounting
13	CICP---	cerniera intermedia per tubo profilato intermediate hinge for profile tube
14	CICT---	cerniera intermedia per tiranti intermediate hinge for tie rod

POS.	CODE	DESCRIZIONE-DESCRIPTION
15	SCI---	supporto cerniera intermedia support for intermediate hinge
16	DA--x---	dado - nut
17	FC--x---	forcella con clips clevis with lockable pin
18	FP--x---	forcella con perno - clevis with pin
19	SSFI--x---	snodo sferico - rod eye
20	SA--x---	snodo autoallineante self-aligning joint
21	BH---	bloccastelo - rod lock
22	GH---...-	unità di guida - guide unit
23	BLW---	soffietto modulare - modular bellows
24	36.TIR---	adattatore sensore - sensor mounting
25	36.SEN---	seniore magnetico - magnetic sensor
26	SFV1M4	staffa fissaggio valvola fixing valve bracket
27	FLCI---	flangia cilindri contrapposti rear opposed cylinder flange
28	FLTI---	flangia cilindri tandem e più posizioni tandem and multi-position flange

Fissaggi forniti con viti - Mounting parts supplied with screws

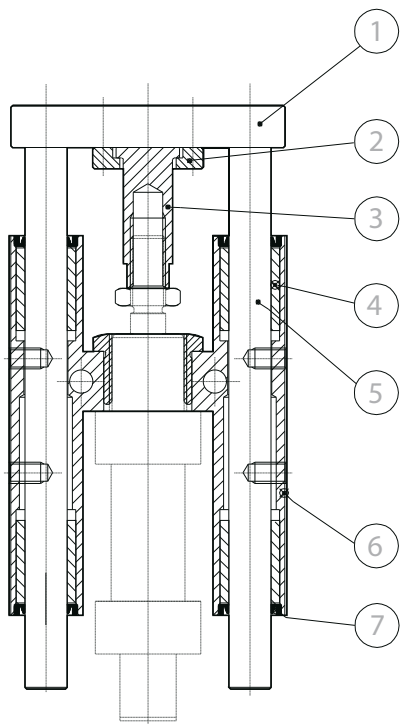
GUIDE UNIT

CARATTERISTICHE COSTRUTTIVE - CONSTRUCTIVE CHARACTERISTICS

①	Piastra - Plate	alluminio anodizzato - anodized aluminium
②	Ghiera - Slotted nut	acciaio zincato - zinc coated steel
③	Giunto - coupling	acciaio zincato - zinc coated steel
④	Boccola guida - Slide bearing	bronzo - bronze
⑤	Stelo - Rod	acciaio cromato - chromed steel
⑥	Corpo - Body	alluminio anodizzato - anodized aluminium
⑦	Raschiastelo - Scraper	NBR

CHIAVE DI CODIFICA
KEY CODE
G H X 0 5 0 . 1 0 0 . S

		ALESAGGIO - BORE (Ø)	CORSA - STROKE (mm)	GIUNTO - COUPLING
		032-040-050-063-080-100	050-100-160-200 250-320-400-500 600-700-800-900-1000	S giunto corto short coupling
VERSIONE - VERSION				
H	tipo H con boccole in bronzo H type with bronze bushes			
HX	tipo H con boccole in bronzo e steli in acciaio inox AISI 304 H type with bronze bushes and AISI 304 SS rods			
HS	tipo H con cuscinetti a ricircolo di sfere e steli in acciaio cromato H type with recirculating ball bearings and chromed steel rods			
U	tipo U con boccole in bronzo U type with bronze bushes			
UX	tipo U con boccole in bronzo e steli in acciaio inox AISI 304 U type with bronze bushes and AISI 304 SS rods			
L giunto lungo long coupling				

SERIE - SERIES
G unità di guida
guide unit

DIAGRAMMA CARICO AMMISSIBILE

ALLOWABLE LOAD



DIAGRAMMA CARICO AMMISSIBILE

ALLOWABLE LOAD

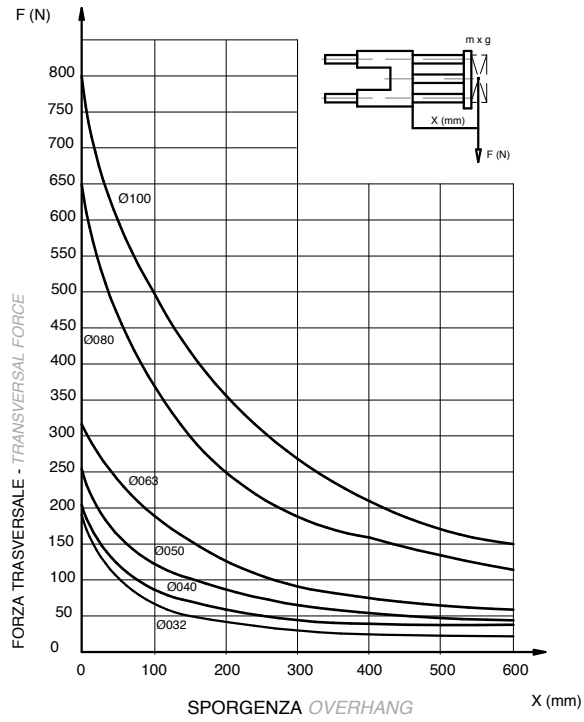

DIAGRAMMA CARICO AMMISSIBILE

ALLOWABLE LOAD

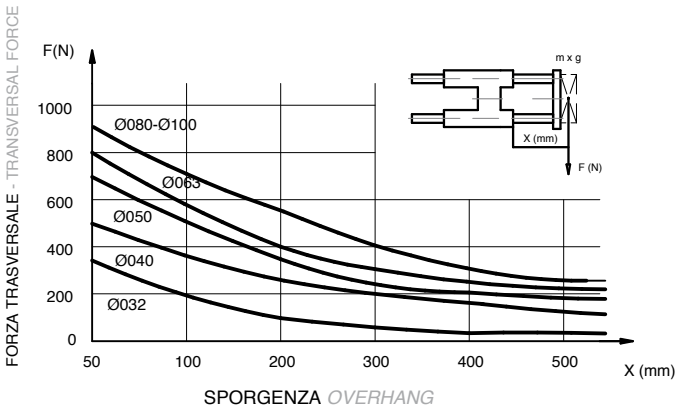
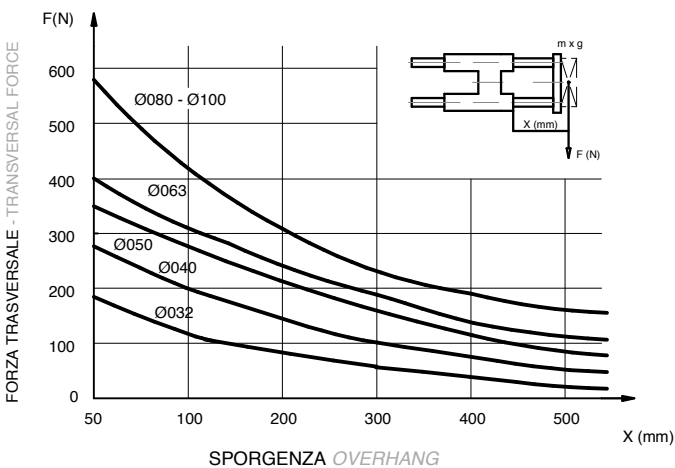
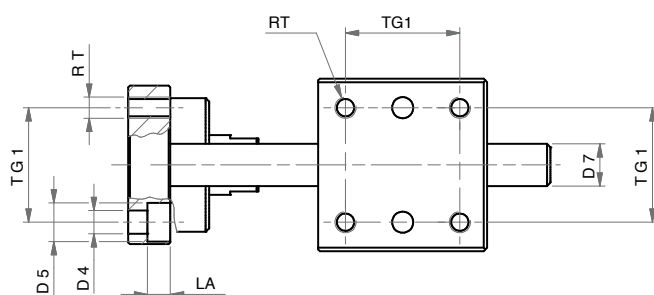
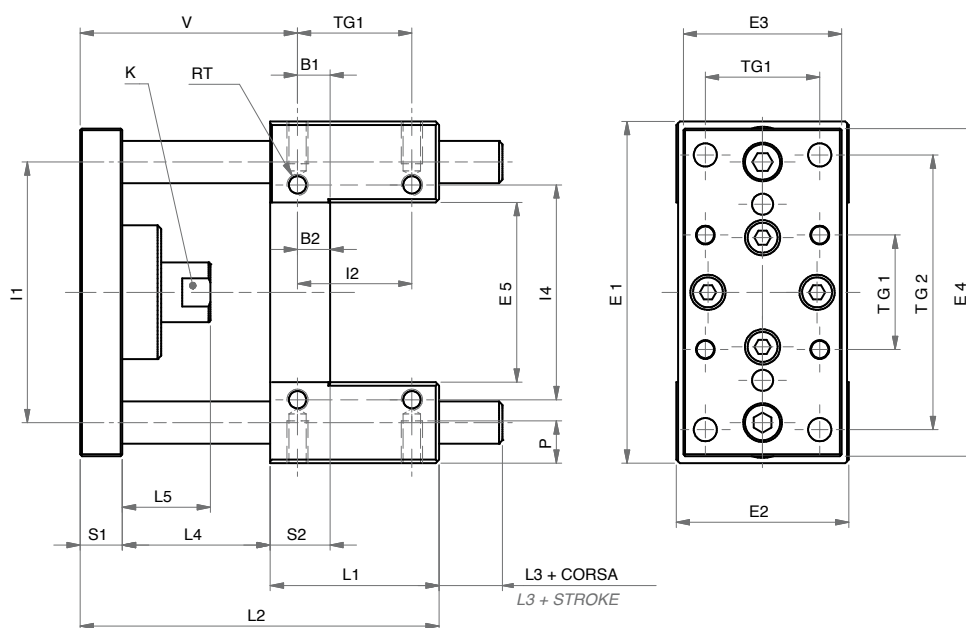

DIMENSIONI
DIMENSIONS

GIUNTO LUNGO - LONG COUPLING

Ø	L4	L5	L3	V
32	25	42	25	82,7
40	25	42	30	86
50	25	50	35	91,2
63	25	50	25	96,7
80	25	50	27	104
100	25	50	27	105

GIUNTO CORTO - SHORT COUPLING

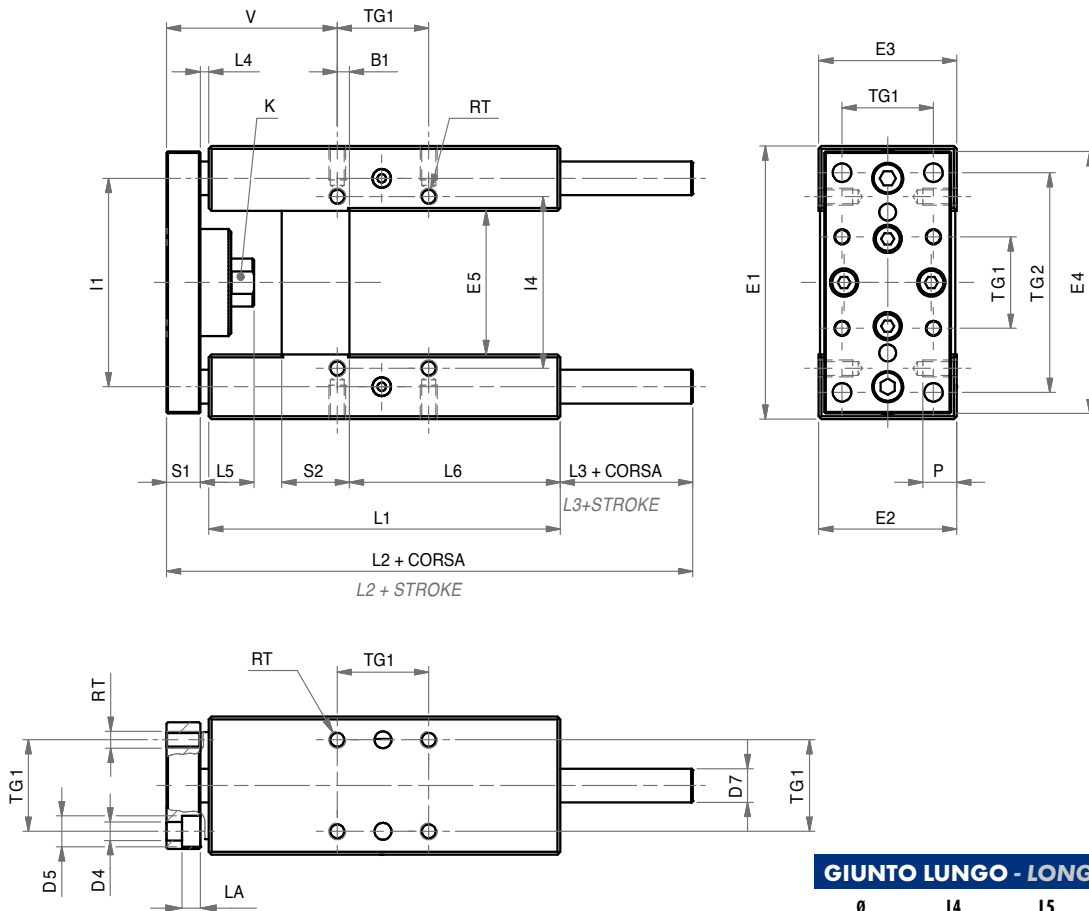
Ø	B1	B2	D4	D5	D7	E1	E2	E3	E4	E5	I1	I2	I4	K	L1	L2	L3	L4	L5	LA	P	RT	S1	S2	TG1	TG2	V
32	9,25	9,25	6,6	11	12	97	49	45	93	51	74	32,5	61	15	48	102	18	42	25	6,5	12	M6	12	17	32,5	78	61,75
40	11	11	6,6	11	16	115	58	55	112	58,2	87	38	69	15	58	113	17	43	25	6,5	12	M6	12	21	38	84	65
50	18,8	18,8	9	15	20	137	70	65	134	70,2	104	46,5	85	20	59	123	20	49	29	8,5	16	M8	15	25	46,5	100	70,2
63	15,3	15,3	9	15	20	152	85	80	147	85,2	119	56,5	100	20	76	140	21	49	29	9	16	M8	15	25	56,5	105	73,7
80	25	14	11	18	25	189	105	100	180	105,5	148	50	130	26	90	163	30	53	37	11	20	M10	20	34	72	130	82
100	28,5	19	10,5	16,5	25	23	130	120	206	130,5	173	70	150	26	110	184	30	54	37	11	20	M10	20	39	89	150	84,5



GIUNTO LUNGO - LONG COUPLING

Ø	L4	L5	L3	V
32	25	42	25	82,7
40	25	42	30	86
50	25	50	35	91,2
63	25	50	25	96,7
80	25	50	27	104
100	25	50	27	105

GIUNTO CORTO - SHORT COUPLING

Ø	B1	D4	D5	D7	E1	E2	E3	E4	E5	I1	I4	K	L1	L2	L3	L4	L5	L6	LA	P	RT	S1	S2	TG1	TG2	V
32	4,3	6,6	11	12	97	49	45	93	51	74	61	15	125	187	47	3	19,1	75	6,5	12	M6	12	24	32,5	78	60,7
40	11	6,6	11	16	115	58	55	112	58,2	87	69	15	140	207	52	3	24	80	6,5	12	M6	12	28	38	84	64
50	18,8	9	15	20	137	70	65	134	70,2	104	85	20	148	223	57	3	27	78	8,5	16	M8	15	34	46,5	100	69,2
63	15,3	9	15	20	152	85	80	147	85,2	119	100	20	178	243	47	3	27	106	9	16	M8	15	34	56,5	105	74,7
80	25	11	18	25	189	105	100	180	105,5	148	130	26	195	267	49	3	27	111	11	20	M10	20	50	72	130	82
100	30	11	18	25	213	130	120	206	130,5	173	150	26	218	290	49	3	27	128	11	20	M10	20	55	89	150	83

BLOCCASTELO
ROD LOCK
CARATTERISTICHE TECNICHE - TECHNICAL CHARACTERISTICS

Pressione di esercizio - Working pressure	3 ÷ 6 bar							
Temperatura di esercizio - Working temperature	-5 ÷ +80°C (con aria secca - with dry air)							
Alesaggi - Bores	ø 032 - 040 - 050 - 063 - 080 - 100 - 125							
Tipo di bloccaggio - Type of locking	Meccanico bidirezionale - Mechanical bi-directional							
Fluido - Fluid	aria compressa filtrata, non lubrificata - compressed filtered, non lubricated air							
Forza bloccaggio - Locking force	ø	32	40	50	63	80	100	125
	[N]	790	1240	1930	3060	5400	7700	12040

ATTENZIONE

Il funzionamento del bloccastelo è di tipo statico (stelo cilindro non in movimento). È necessario arrestare lo stelo del cilindro prima di effettuare il bloccaggio. È possibile sbloccare il bloccastelo solo se le forze nel pistone sono equilibrate, altrimenti si possono verificare incidenti a causa del movimento irregolare dello stelo. Se vengono superati i valori di bloccaggio indicati, si possono verificare slittamenti dello stelo. In condizioni di bloccaggio e con carichi variabili sullo stelo, lo stelo può avere un leggero gioco assiale.

Non togliere l'alimentazione dell'aria in assenza del falso stelo o dello stelo del cilindro

ATTENTION

Rod lock's functioning is of static type (cylinder rod must be stopped). It is necessary to stop the cylinder rod before locking it. It is possible to unblock the rod lock only if the forces in the piston are balanced, otherwise there can be accidents due to the irregular movement of the rod. If the given blocking values are exceeded there can be a sliding on the rod. When it is blocked and the loads are variable on the rod, the rod can have a slight axial play.

Don't remove air feeding when "false" rod or cylinder rod is missing.

CARATTERISTICHE COSTRUTTIVE - CONSTRUCTIVE CHARACTERISTICS

①	Boccola - Bush	delrin
②	Dado - Nut	acciaio zincato - zinc coated steel
③ ④	Molla - Spring	acciaio - steel
⑤ ⑦	Coperchio - Cover	alluminio - aluminium
⑥	Guarnizioni - Seals	poliuretano - polyurethane
⑧ ⑬	Guarnizioni - Seals	NBR
⑨	Pistone - Piston	delrin
⑩	Disco molla - Spring cover	delrin
⑪	Corpo - Body	alluminio anodizzato - anodized aluminium
⑫	Palette - Jaws	bronzo - bronze
	Viti - Screws	acciaio zincato - zinc coated steel

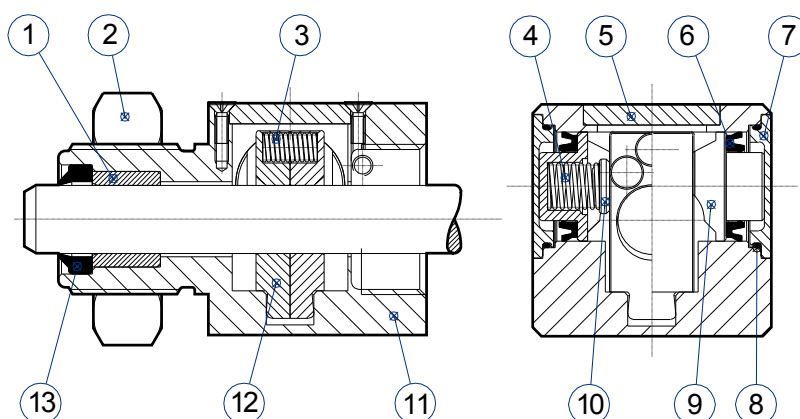

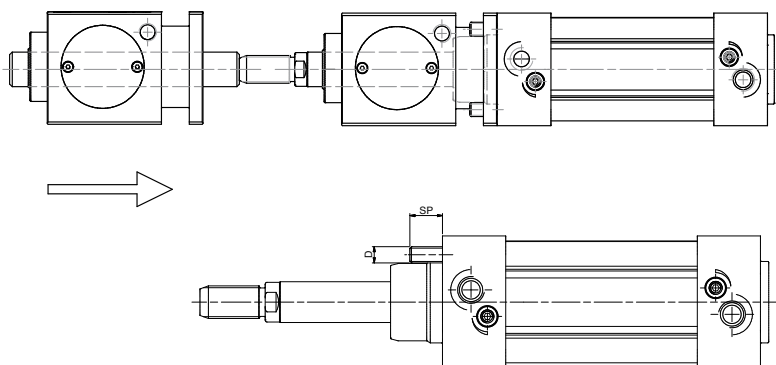
MONTAGGIO - INSTALLATION

CILINDRO \varnothing - \varnothing CYLINDER	32	40	50	63	80	100	125
SP	12	12	16	16	22	22	32
D	M6	M6	M8	M8	M10	M10	M12

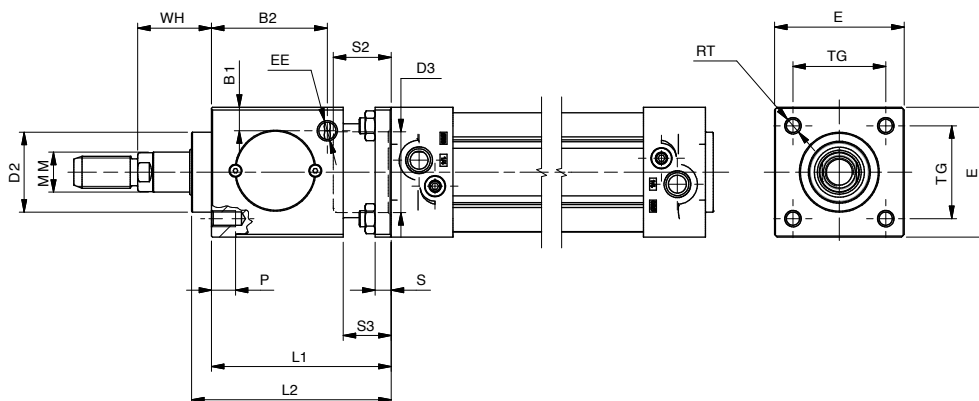
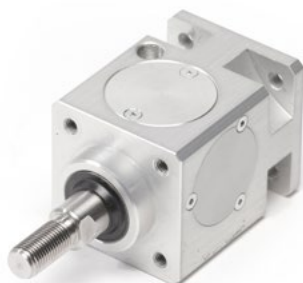

DIMENSIONI - DIMENSION

COD.	B1	B2	\varnothing D2	D3	E	EE	L1	L2	\varnothing MM	P	RT	S	S2	S3	TG	WH
BH032	9	33,25	30	30,5	47	1/8"G	60	67,5	12	8	M6	6	19,5	20	32,5	26
BH040	9	42,5	34,9	35,5	54	1/8"G	70	80	16	8	M6	6	22,5	20	38	30
BH050	12,5	58	40	40,5	65	1/8"G	90	100	20	12	M8	8	29	24	46,5	37
BH063	17,5	59	45	45,5	75	1/8"G	90	100	20	12	M8	8	29	24	56,5	37
BH080	17,5	69	45	45,5	95	1/4"G	110	120	25	16	M10	12	37	32	72	46
BH100	20	69	55	55,5	114	1/4"G	110	120	25	16	M10	12	39	32	89	51
BH125	19	84,5	60	60,5	138	1/4"G	140	156	32	20	M12	20	51,5	45	110	65

!!!: Non togliere l'alimentazione dell'aria in assenza dello stelo - Don't stop air in the absence of the rod

Il funzionamento del bloccastele è di tipo statico (stelo non in movimento). È necessario arrestare lo stelo del cilindro prima di effettuare il bloccaggio.

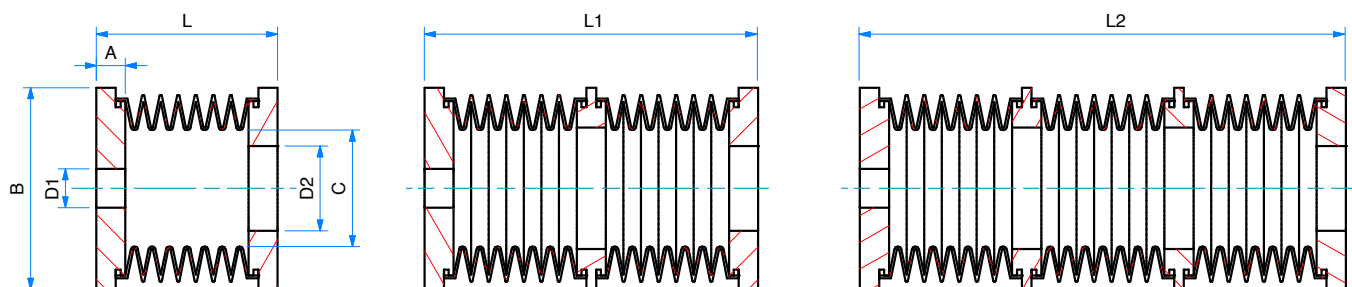
The rod lock operation is static (rod not moving). The rod must be stopped before locking.

SOFFIETTO MODULARE
MODULAR BELLOWS

DIMENSIONI - DIMENSION

		SERIE 60	SERIE 83	SERIE 106	SERIE 106L
\varnothing		32	40-50-63-80	100-125-160	100-125
A		12	12	12	12
B		60	83	106	106
D1-D2	min	10	10	10	10
	max	40	60	80	80
C		30	50	70	55
L senza giunzioni - without joints	chiuso - closed	55	65	40	100
	aperto - open	300	350	220	750
L1 (1 giunzione - 1 joint)	chiuso - closed	110	130	80	200
	aperto - open	600	700	440	1500
L2 (2 giunzioni - 2 joints)	chiuso - closed	165	195	120	300
	aperto - open	900	1050	660	2250

DIMENSIONI - DIMENSION

CILINDRO - CYLINDER	SOFFIETTO SERIE BELLOW SERIE	Senza giunzioni - Without joints		1 giunzione - with 1 joint		2 giunzioni - with 2 joints	
		WH cylinder	Max stroke	WH cylinder	Max stroke	WH cylinder	Max stroke
H032	BLW60	66	245	126	490	186	735
H040	BLW83	78	285	148	570	218	855
H050	BLW83	80	285	150	570	220	855
H063	BLW83	80	285	150	570	220	855
H080	BLW83	83	285	149	570	219	855
H100	BLW106	64	180	96	360	144	540
H100	BLW106L	122	640	227	1290	332	1930
H125	BLW106	75	180	105	360	147	540
H125	BLW106L	122	640	227	1290	332	1930

CERNIERA MASCHIO ISO (MP4)

ISO MALE HINGE (MP4)

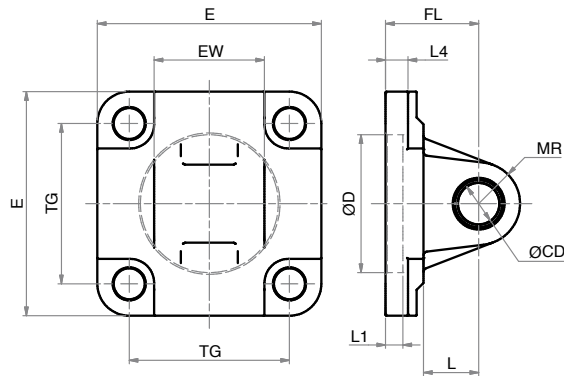

LA FORNITURA COMPRENDE:
n° 1 CERNIERA MASCHIO
n° 4 VITI
THE SUPPLY INCLUDES:
n° 1 MALE HINGE
n° 4 SCREWS

MATERIALE:
CORPO IN ALLUMINIO
BOCCOLA IN ACCIAIO E PTFE
MATERIAL:
BODY IN ALUMINIUM
BUSH IN STEEL AND PTFE

DIMENSIONI - DIMENSIONS

COD.	CMI032	CMI040	CMI050	CMI063	CMI080	CMI100	CMI125
Ø	32	40	50	63	80	100	125
EW	26	28	32	40	50	60	70
E	45	52	65	75	93	110	134
FL	22	25	27	32	36	41	50
L1	5	5	5	5	5	5	7
L4	5,5	5,5	6,5	6,5	10	10	10
L	13	16	16	21	22	27	30
MR	10	12	12	16	16	20	25
Ø CD	10	12	12	16	16	20	25
Ø D	30	35	40	45	45	55	60
TG	32,5	38	46,5	56,5	72	89	110

CERNIERA FEMMINA ISO (MP2)

ISO FEMALE HINGE (MP2)

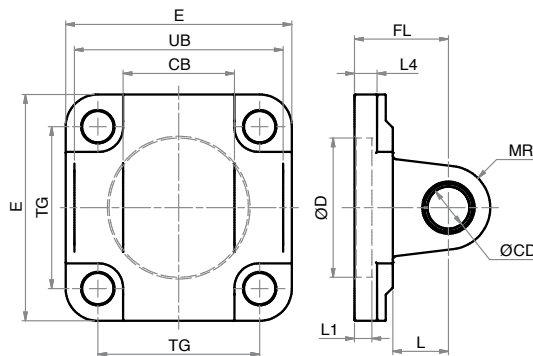

LA FORNITURA COMPRENDE:
n° 1 CERNIERA FEMMINA
n° 4 VITI
THE SUPPLY INCLUDES:
n° 1 FEMALE HINGE
n° 4 SCREWS

MATERIALE:
CORPO IN ALLUMINIO
BOCCOLA IN ACCIAIO E PTFE
MATERIAL:
BODY IN ALUMINIUM
BUSH IN STEEL AND PTFE

DIMENSIONI - DIMENSIONS

COD.	CFI032	CFI040	CFI050	CFI063	CFI080	CFI100	CFI125
Ø	32	40	50	63	80	100	125
CB	26	28	32	40	50	60	70
E	45	52	65	75	93	110	134
FL	22	25	27	32	36	41	50
L1	5	5	5	5	5	5	7
L4	5,5	5,5	6,5	6,5	10	10	10
L	13	16	16	21	22	27	30
MR	10	12	12	16	16	20	25
Ø CD	10	12	12	16	16	20	25
Ø D	30	35	40	45	45	55	60
TG	32,5	38	46,5	56,5	72	89	110
UB	45	52	60	70	90	110	130

*CFI---F dimensione foro centrale uguale alla quota ØD - *CFI---F dimension of the central hole are the same as ØD

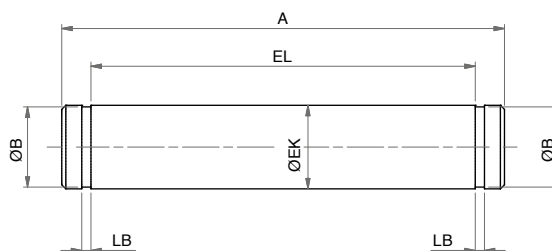
PERNO PER CERNIERA (AA4)
PIN FOR HINGE (AA4)

LA FORNITURA COMPRENDE:

n°1 PERNO

n°2 SEEGER

THE SUPPLY INCLUDES:

n°1 PIN

n°2 RETAINING RING

MATERIALE:

ACCIAIO ZINCATO

MATERIAL:

ZINC COATED STEEL

DIMENSIONI - DIMENSIONS

COD.	PCF032	PCF040	PCF050	PCF063	PCF080	PCF100	PCF125
Ø	32	40	50	63	80	100	125
A	53	60	68	78	98	118	139
EL	46	53	61	71	91	111	132
LB	1,1	1,1	1,1	1,1	1,1	1,3	1,3
Ø B	9,6	11,5	11,5	15,2	15,2	19	23,9
Ø EK	10	12	12	16	16	20	25

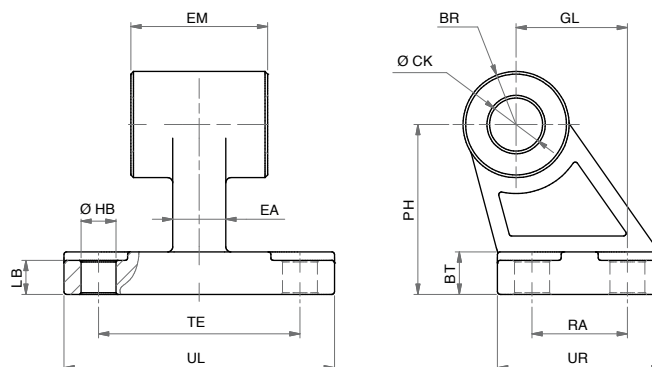
ARTICOLAZIONE A SQUADRA ISO (AB7)
ISO SQUARE HINGE (AB7)

LA FORNITURA COMPRENDE:

n°1 ARTICOLAZIONE A SQUADRA

THE SUPPLY INCLUDES:

n°1 SQUARE HINGE

MATERIALE:

CORPO IN ALLUMINIO

BOCCOLA IN ACCIAIO E PTFE

MATERIAL:

BODY IN ALUMINIUM

BUSH IN STEEL AND PTFE

DIMENSIONI - DIMENSIONS

COD.	ASI032	ASI040	ASI050	ASI063	ASI080	ASI100	ASI125
Ø	32	40	50	63	80	100	125
BR	10	11	13	15	15	19	22,5
BT	8	10	12	14	14	17	20
Ø CK	10	12	12	16	16	20	25
EA	10	15	16	16	20	20	30
EM	26	28	32	40	50	60	70
GL	21	24	33	37	47	55	70
LB	6,4	8,4	10,4	12,4	11,5	14,5	16,8
Ø HB	6,6	6,6	9	9	11	11	14
PH	32	36	45	50	63	71	90
RA	18	22	30	35	40	50	60
TE	38	41	50	52	66	76	94
UL	51	54	65	67	86	96	124
UR	31	35	45	50	60	70	90

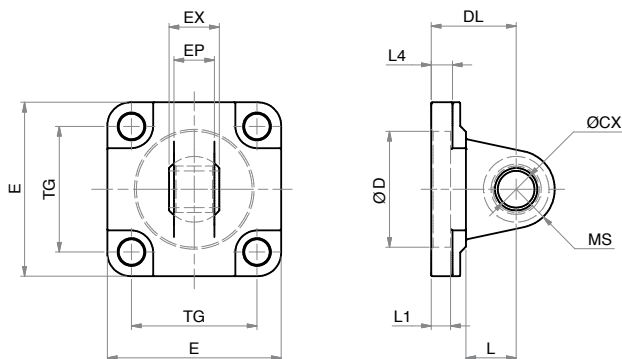
SERIE H CERNIERA MASCHIO SNODATA ISO (MP6)
ISO MALE HINGE WITH BALL JOINT (MP6)

LA FORNITURA COMPRENDE:
 n° 1 CERNIERA MASCHIO
 n° 4 VITI
 THE SUPPLY INCLUDES:
 n° 1 MALE HINGE
 n° 4 SCREWS

MATERIALE:
 CORPO IN ALLUMINIO
 SNODO IN ACCIAIO,
 BRONZO E PTFE
 MATERIAL:
 BODY IN ALUMINIUM
 EYE IN STEEL, BRONZE AND PTFE

DIMENSIONI - DIMENSIONS

COD.	CMSI032	CMSI040	CMSI050	CMSI063	CMSI080	CMSI100	CMSI125
Ø	32	40	50	63	80	100	125
DL	22	25	27	32	36	41	50
EP	10,5	12	15	15	18	18	25
EX	14	16	21	21	25	25	37
E	45	52	65	75	95	115	140
L1	7	7	7	7	9	9	9
L4	5,5	5,5	6,5	6,5	10	10	10
L	12	15	15	20	20	25	30
MS	16	18	21	23	28	30	40
Ø CX	10	12	16	16	20	20	30
Ø D	30	35	40	45	45	55	60
TG	32,5	38	46,5	56,5	72	89	110

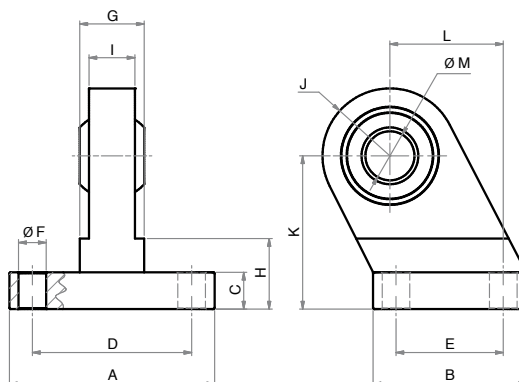
ARTICOLAZIONE A SQUADRA SNODATA
ISO SQUARE HINGE WITH BALL JOINT

LA FORNITURA COMPRENDE:
 n° 1 ARTICOLAZIONE A SQUADRA
 THE SUPPLY INCLUDES:
 n° 1 SQUARE HINGE

MATERIALE:
 CORPO IN ALLUMINIO
 SNODO IN ACCIAIO,
 BRONZO E PTFE
 MATERIAL:
 BODY IN ALUMINIUM
 EYE IN STEEL, BRONZE AND PTFE

DIMENSIONI - DIMENSIONS

COD.	ASSI032	ASSI040	ASSI050	ASSI063	ASSI080	ASSI100
Ø	32	40	50	63	80	100
A	51	54	65	67	86	96
B	31	35	45	50	60	70
C	10	10	12	12	14	15
D	38	41	50	52	66	76
E	18	22	30	35	40	50
G	14	16	21	21	25	25
H	16	16	21	23	32	33
I	10,5	12	15	15	18	18
J	15	17	20	22	27	29
K	32	36	45	50	63	71
L	21	24	33	37	47	55
Ø F	6,6	6,6	9	9	11	11
Ø M	10	12	16	16	20	20

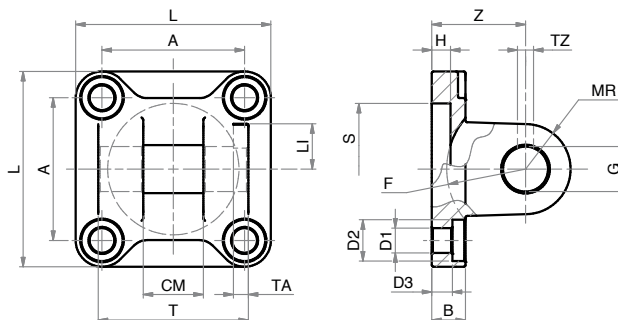
CERNIERA FEMMINA STRETTA ISO (AB6)
ISO NARROW FEMALE HINGE (AB6)

LA FORNITURA COMPRENDE:
 n° 1 CERNIERA FEMMINA
 n° 4 VITI
 THE SUPPLY INCLUDES:
 n° 1 FEMALE HINGE
 n° 4 SCREWS

MATERIALE: ALLUMINIO
 MATERIAL: ALUMINIUM

DIMENSIONI - DIMENSIONS

COD.	CFSI032	CFSI040	CFSI050	CFSI063	CFSI080	CFSI100	CFSI125
ø	32	40	50	63	80	100	125
A	32,5	38	46,5	56,5	72	89	110
B	9	9	11	11	14	14	20
CM	14	16	21	21	25	25	37
D1	6,6	6,6	9	9	11	11	14
D2	11	11	15	15	18	18	20
D3	5,5	5,5	6,5	6,5	10	10	10
F min.	17	20	22	25	30	32	42
G	10	12	16	16	20	20	30
H	5	5	5	5	5	5	7
LI	11,5	12	14	14	16	16	24
L	45	52	65	75	95	115	140
MR	10	12	14	18	20	22	25
S	30	35	40	45	45	55	60
TA	3	4	4	4	4	4	6
TZ	3,3	4,3	4,3	4,3	4,3	6,3	6,3
T	34	40	45	51	65	75	97
Z	22	25	27	32	36	41	50

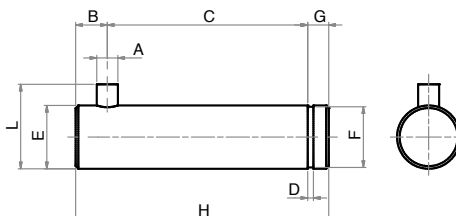
PERNO PER CERNIERA STRETTA (AA6)
PIN FOR NARROW HINGE (AA6)

LA FORNITURA COMPRENDE:
 n° 1 PERNO
 n° 1 SEEGER
 THE SUPPLY INCLUDES:
 n° 1 PIN
 n° 1 RETAINING RING

MATERIALE:
 ACCIAIO ZINCATO
 MATERIAL:
 ZINC COATED STEEL

DIMENSIONI - DIMENSIONS

COD.	PCFS032	PCFS040	PCFS050	PCFS063	PCFS080	PCFS100	PCFS125
ø	32	40	50	63	80	100	125
A	3	4	4	4	4	4	6
B	4,5	6	6	6	6	6	9
C	32,5	38	43	49	63	73	94
D	1,1	1,1	1,1	1,1	1,3	1,3	1,6
E	10	12	16	16	20	20	30
F	9,6	11,5	15,2	15,2	19	19	28,6
G	4	4	5	5	6	6	7
H	41	48	54	60	75	85	110
L	14	16	20	20	24	24	36

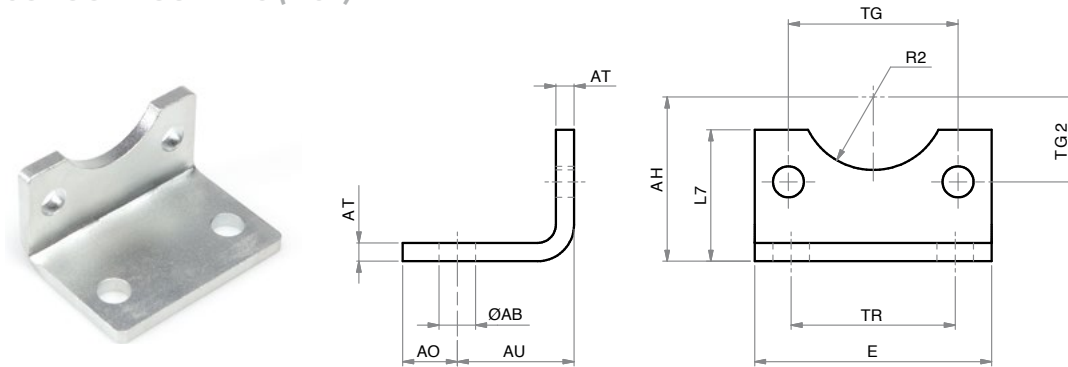
PIEDINO BASSO ISO (MS1)
ISO FOOT MOUNTING (MS1)

LA FORNITURA COMPRENDE:
 n° 1 PIEDINO
 n° 2 VITI
 THE SUPPLY INCLUDES:
 n° 1 FOOT MOUNTING
 n° 2 SCREWS

MATERIALE:
 ACCIAIO ZINCATO
 MATERIAL:
 ZINC COATED STEEL

DIMENSIONI - DIMENSIONS

COD.	PBI032	PBI040	PBI050	PBI063	PBI080	PBI100	PBI125
Ø	32	40	50	63	80	100	125
AH	32	36	45	50	63	71	90
AO	11	8	15	13	14	16	25
AT	4	4	5	5	6	6	8
AU	24	28	32	32	41	41	45
E	45	52	65	75	95	115	140
L7	30	30	36	35	47	53	70
Ø AB	7	10	10	10	12	14,5	16,5
R2	15	17,5	20	22,5	22,5	27,5	30
TG2	16,25	19	23,25	28,25	36	44,5	55
TG	32,5	38	46,5	56,5	72	89	110
TR	32	36	45	50	63	75	90

A richiesta - On request Ø 250-320

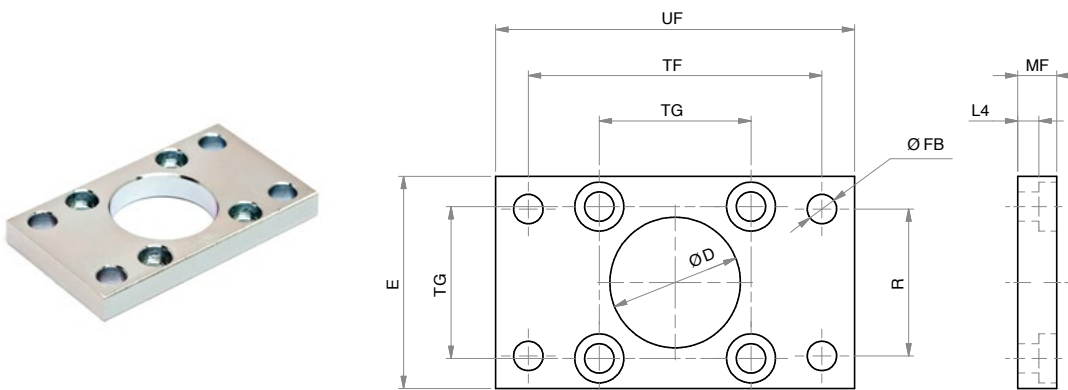
FLANGIA ISO (MF1 - MF2)
ISO FLANGE (MF1 - MF2)

LA FORNITURA COMPRENDE:
 n° 1 FLANGIA
 n° 4 VITI
 THE SUPPLY INCLUDES:
 n° 1 FLANGE
 n° 4 SCREWS

MATERIALE:
 ACCIAIO ZINCATO
 MATERIAL:
 ZINC COATED STEEL

DIMENSIONI - DIMENSIONS

COD.	FI032	FI040	FI050	FI063	FI080	FI100	FI125
Ø	32	40	50	63	80	100	125
E	45	52	65	75	95	115	140
L4	5	5	6,5	6,5	9	9	10,5
MF	10	10	12	12	16	16	20
Ø D	30	35	40	45	45	55	60
Ø FB	7	9	9	9	12	14	16
R	32	36	45	50	63	75	90
TF	64	72	90	100	126	150	180
TG	32,5	38	46,5	56,5	72	89	110
UF	80	90	110	120	150	170	205

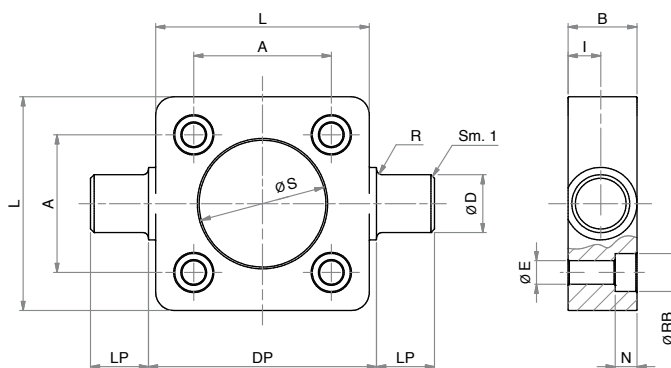
CERNIERA ANTERIORE-POSTERIORE LAMATA
FRONT-REAR HINGE

LA FORNITURA COMPRENDE:

n° 1 CERNIERA

n° 4 VITI

THE SUPPLY INCLUDES:

n° 1 HINGE

n° 4 SCREWS

MATERIALE:

ACCIAIO ZINCATO

MATERIAL:

ZINC COATED STEEL

DIMENSIONI - DIMENSIONS

COD.	CIA032	CIA040	CIA050	CIA063	CIA080	CIA100	CIA125
ø	32	40	50	63	80	100	125
A	32,5	38	46,5	56,5	72	89	110
B	14	19	19	24	24	29	30
ø D	12	16	16	20	20	25	25
DP	50	63	75	90	110	132	160
øE	6,5	6,5	8,5	8,5	10,5	10,5	13,5
I	6,5	9	9	11,5	11,5	14	15
L	46	59	69	84	102	125	150
LP	12	16	16	20	20	25	25
N	6	6	8	8	10	10	12
R	1	1,5	1,6	1,6	1,6	2	2
ø RB	10,5	10,5	13,5	13,5	16,5	16,5	20
ø S	30	35	40	45	45	55	60

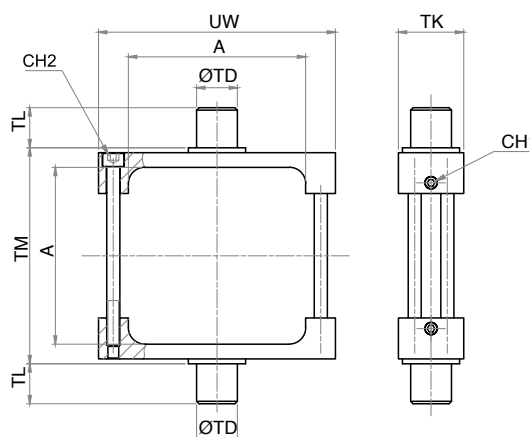
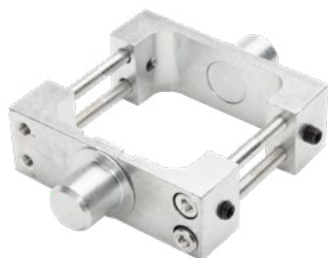
CERNIERA INTERMEDIA PER TUBO PROFILATO SERIE H
INTERMEDIATE HINGE FOR SERIE H PROFILE TUBE

LA FORNITURA COMPRENDE:

n° 1 PIEDINO

n° 2 VITI

THE SUPPLY INCLUDES:

n° 1 FOOT MOUNTING

n° 2 SCREWS

MATERIALE:

ACCIAIO ZINCATO

MATERIAL:

ZINC COATED STEEL

DIMENSIONI - DIMENSIONS

COD.	CICP032	CICP040	CICP050	CICP063	CICP080	CICP100	CICP125
ø	32	40	50	63	80	100	125
A	45	51,8	60,7	72,2	91,2	108,2	135,3
CH1	3	3	3	3	3	4	4
CH2	3	4	5	5	5	6	6
ø TD	12	16	16	20	20	25	25
TK	25	25	30	30	30	40	40
TL	11,5	16	16	20	20	24,5	24,5
TM	50	63	75	90	110	132	160
UW	65	75	95	105	130	145	176

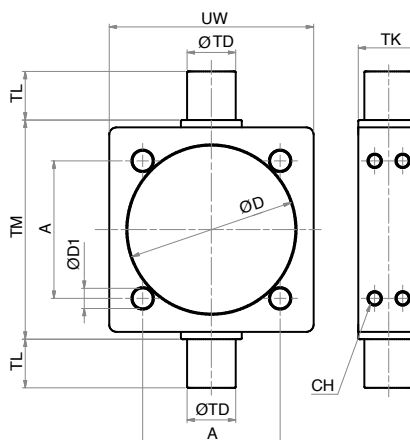
CERNIERA INTERMEDIA PER TIRANTI (MT4)
CICT
INTERMEDIATE HINGE FOR TIE RODS (MT4)

LA FORNITURA COMPRENDE:
 n°1 CERNIERA INTERMEDIA
 THE SUPPLY INCLUDES:
 n°1 INTERMEDIATE HINGE

MATERIALE:
 ACCIAIO ZINCATO
 MATERIAL:
 ZINC COATED STEEL

DIMENSIONI - DIMENSIONS

COD.	CICT032	CICT040	CICT050	CICT063	CICT080	CICT100	CICT125
Ø	32	40	50	63	80	100	125
A	32,5	38	46,5	56,5	72	89	110
CH	2,5	2,5	3	3	4	4	5
Ø D1	6,25	6,25	8,25	8,25	10,25	10,25	12,25
Ø D	37	46	56	69	87	107	133
Ø TD	12	16	16	20	20	25	25
TK	15	20	20	25	25	30	32
TL	12	16	16	20	20	25	25
TM	50	63	75	90	110	132	160
UW	46	59	69	84	102	125	155

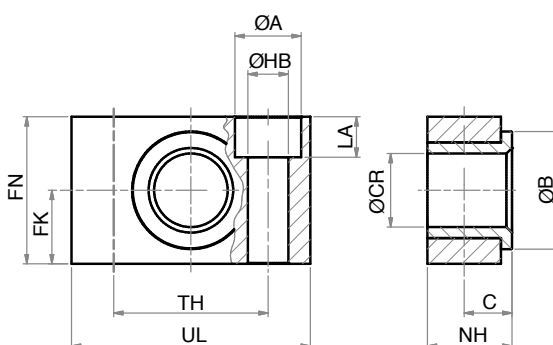
SUPPORTO PER CERNIERA INTERMEDIA (AT4)
SCI
SUPPORT FOR INTERMEDIATE HINGE (AT4)

LA FORNITURA COMPRENDE:
 N° 1 SUPPORTO
 N° 2 VITI
 THE SUPPLY INCLUDES:
 n° 1 SUPPORT
 n°2 SCREWS

MATERIALE:
 CORPO IN ALLUMINIO
 BOCCOLA IN BRONZO
 MATERIAL:
 BODY IN ALUMINIUM
 BUSH IN BRONZE

DIMENSIONI - DIMENSIONS

COD.	SCI032	SCI040.050	SCI063.080	SCI100.125
Ø	32	40-50	63-80	100-125
C	10,5	12	13	16
FK	15	18	20	25
FN	30	36	40	50
LA	7	9	11	13
NH	18	21	23	28,5
Ø A	11	15	18	20
Ø B	22	28	32	39
Ø CR	12	16	20	25
Ø HB	6,6	9	11	14
TH	32	36	42	50
UL	46	55	65	75

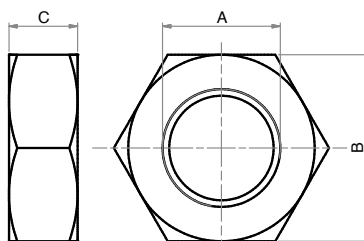
DADO STELO
PISTON ROD NUT

MATERIALE:
ACCIAIO ZINCATO
MATERIAL:
ZINC COATED STEEL

DIMENSIONI - DIMENSIONS

COD.	DA10x1,25	DA12x1,25	DA16x1,5	DA20x1,5	DA27x2
A	M10x1,25	M12x1,25	M16x1,5	M20x1,5	M27x2
B	17	19	24	30	41
C	6	7	8	9	12

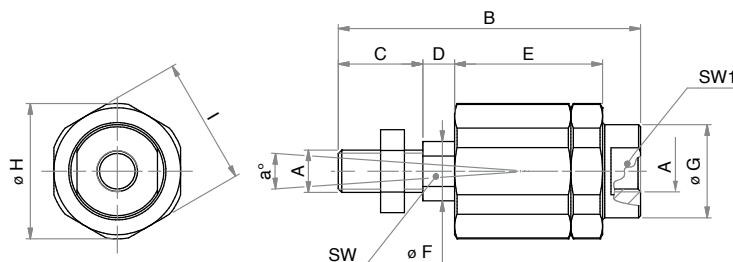
SNODO AUTOALLINEANTE
SELF-ALIGNING COUPLING

LA FORNITURA
COMPRENDE:
n° 1 SNODO
AUTOALLINEANTE
n° 1 DADO
THE SUPPLY INCLUDES:
n° 1 SELF ALIGNING
n° 1 NUT

MATERIALE:
ACCIAIO ZINCATO
MATERIAL:
ZINC COATED STEEL

DIMENSIONI - DIMENSIONS

COD.	SA10x1,25	SA12x1,25	SA16x1,5	SA20x1,5	SA27x2
A	M10x1,25	M12x1,25	M16x1,5	M20x1,5	M27x2
α°	8	8	8	8	8
B	71	74,5	104	120	158
C	20	24	32	40	54
D	7	7,5	7	8	13
E	36	36	53	53	79
ø F	14	14	22	22	28
ø G	21,5	21,5	34	34	45
ø H	32	32	45	45	62
I	30	30	41	41	55
SW	12	12	19	19	24
SW1	19	19	30	30	41

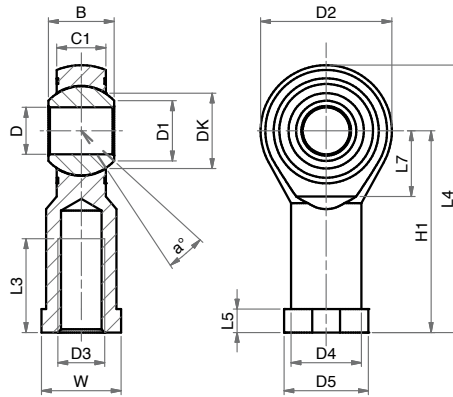
SNODO SFERICO FILETTO INTERNO
ROD EYE (INTERNAL THREAD)

MATERIALE:
CORPO IN ACCIAIO ZINCATO
SNODO IN ACCIAIO,
BRONZO E PTFE
MATERIAL:
BODY IN ZINC COATED STEEL
EYE IN STEEL, BRONZE
AND PTFE

DIMENSIONI - DIMENSIONS

COD.	SSF10x1,25	SSF12x1,25	SSF16x1,5	SSF20x1,5	SSF27x2
α°	13	13	15	14	17
B	14	16	21	25	37
C1	10,5	12	15	18	25
D1	12,9	15,4	19,3	24,3	34,8
D2	28	32	42	50	70
D3	M10x1,25	M12x1,25	M16x1,5	M20x1,5	M27x2
D4	15	17,5	22	27,5	40
D5	19	22	27	34	50
DK	19,05	22,22	28,57	34,92	50,8
ø D	10	12	16	20	30
H1	43	50	64	77	110
L3	20	22	28	33	51
L4	57	66	85	102	145
L5	6,5	6,5	8	10	15
L7	15	17	23	27	36
W	17	19	22	30	41

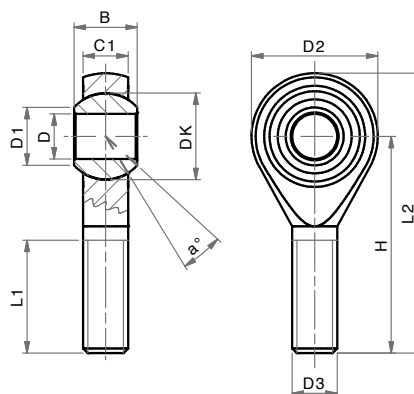
SNODO SFERICO FILETTO ESTERNO
ROD EYE (EXTERNAL THREAD)

MATERIALE:
CORPO IN ACCIAIO ZINCATO
SNODO IN ACCIAIO,
BRONZO E PTFE
MATERIAL:
BODY IN ZINC COATED STEEL
EYE IN STEEL, BRONZE
AND PTFE

DIMENSIONI - DIMENSIONS

COD.	SSF06x1	SSF08x1,25	SSF10x1,5	SSF12x1,75	SSF16x2
α°	13	14	13	13	15
B	9	12	14	16	21
C1	6,75	9	10,5	12	15
D1	8,9	10,4	12,9	15,4	19,3
D2	20	24	28	32	42
D3	M6	M8	M10	M12	M16
DK	12,7	15,87	19,05	22,22	28,57
ø D	6	8	10	12	16
H	36	42	48	54	66
L1	21	25	28	32	37
L2	46	54	62	70	87

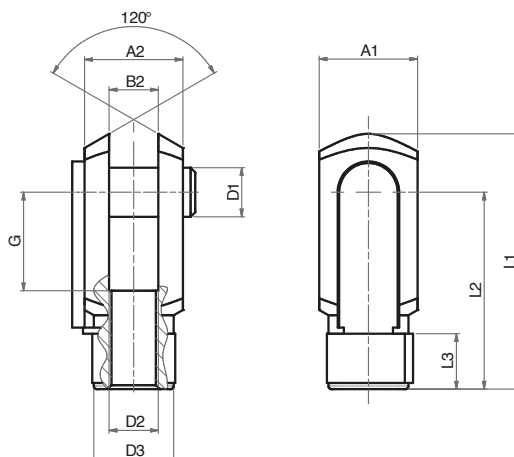
FORCELLA CON CLIPS
CLEVIS WITH LOCKABLE PIN

LA FORNITURA COMPRENDE:

n° 1 FORCELLA

n° 1 CLIPS

THE SUPPLY INCLUDES:

n° 1 FORK

n° 1 LOCKABLE PIN

MATERIALE:

ACCIAIO ZINCATO

MATERIAL:

ZINC COATED STEEL

DIMENSIONI - DIMENSIONS

COD.	FC10x1,25	FC12x1,25	FC16x1,5	FC20x1,5
A1	20	24	32	40
A2	20	24	32	40
B2	10	12	16	20
ø D1	10	12	16	20
D2	M10x1,25	M12x1,25	M16x1,5	M20x1,5
ø D3	18	20	26	34
G	20	24	32	40
L1	52	62	83	105
L2	40	48	64	80
L3	15	18	24	30

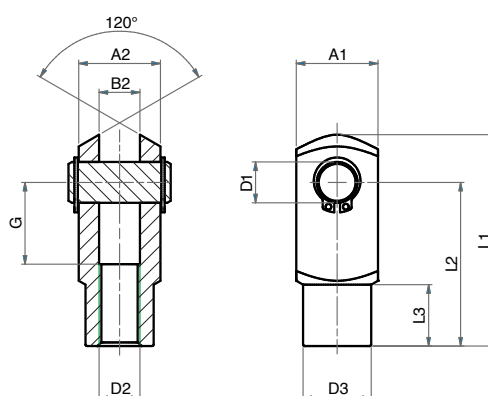
FORCELLA CON PERNO
CLEVIS WITH PIN

LA FORNITURA COMPRENDE:

n° 1 FORCELLA

n° 1 PERNO

n° 2 SEGER

THE SUPPLY INCLUDES:

n° 1 FORK

n° 1 PIN

n° RETAINING RING

MATERIALE:

ACCIAIO ZINCATO

MATERIAL:

ZINC COATED STEEL

DIMENSIONI - DIMENSIONS

COD.	FP10x1,25	FP12x1,25	FP16x1,5	FP20x1,5	FP27x2
A1	20	24	32	40	55
A2	20	24	32	40	55
B2	10	12	16	20	30
ø D1	10	12	16	20	30
D2	M10x1,25	M12x1,25	M16x1,5	M20x1,5	M27x2
ø D3	18	20	26	34	48
G	20	24	32	40	54
L1	52	62	83	105	148
L2	40	48	64	80	110
L3	15	18	24	30	38

SENSORI MAGNETICI

MAGNETIC SENSORS

SERIE

H

CARATTERISTICHE - CHARACTERISTICS					
CODICE - CODE		36.SEN06 36.SEN06.L6	36.SEN07	36.SEN08	36.SEN09 36.SEN09.L6 36.SEN09.L10
TIPO - TYPE		REED	REED	ELETTRONICO ELECTRONIC	ELETTRONICO ELECTRONIC
Modello elettrico - Electrical design		AC/DC PNP/NPN	AC/DC PNP/NPN	DC PNP	DC PNP
Funzione dell'uscita - Output		NO	NO	NO	NO
Tensione di esercizio - Operating voltage	[V]	5...120 AC/DC	5...60 DC / 5...50 AC	10...30 DC	10...30 DC
Capacità di corrente - Current rating	[mA]	100*	100*	100	100
Sensibilità di reazione - Magnetic sensitivity	[mT]	2,1	2,1	2,8	2,8
Velocità di passaggio - Travel speed	[m/s]	> 10	> 10	> 10	> 10
Protezione da cortocircuito - Short-circuit proof		no	no	si - yes	si - yes
Protetto da inversione di polarità Reverse polarity protection		si - yes	si - yes	si - yes	si - yes
Resistente a sovraccarico - Overload protection		no	no	si - yes	si - yes
Caduta di tensione - Voltage drop	[V]	< 5	< 5	< 2,5	< 2,5
Isteresi - Hysteresis		1	1	< 1,5	< 1,5
Riproducibilità - Repeatability	[mm]	± 0,2	± 0,2	< 0,2	< 0,2
Corrente assorbita - Current consumption	[mA]	-	-	< 10	< 10
Tempo di commutazione - Make time	[ms]	≤ 0,6	≤ 0,6	-	-
Tempo di riapertura - Fall time	[ms]	≤ 0,1	≤ 0,1	-	-
Potenza max - Switching power max	[W]	10	10	-	-
Cicli di commutazione con connessione a PLC Switching cycles when connected to PLC	[mln]	≤ 40	≤ 40	-	-
Frequenza di commutazione - Switching frequency	[Hz]	1.000	1.000	> 10.000	> 10.000
Temperatura ambiente - Ambient temperature	[°C]	-25...70	-25...70	-25...80	-25...80
Grado/Classe di protezione - Protection		IP67, II	IP67, II	IP67, III	IP67, III
Materiale involucro - Housing material		PA (poliammide - polyamide)			
Materiale eccentrico di fissaggio - Fastening clamp		inox - stainless steel			
Indicazione della funzione Stato di commutazione Function display Switching status	LED	giallo - yellow			
Collegamento - Connection		cavo PUR - PUR cable 2x0,14 mm ² 2 m (.L6 = 6 m)	cavo PUR - PUR cable connettore M8- M8 connector 0,3 m	cavo PUR - PUR cable connettore M8- M8 connector 0,3 m	cavo PUR - PUR cable 3x0,14 mm ² 2 m (.L6 = 6 m .L10 = 10 m)
Peso - Weight	[g]	31,3 69	12	12,1	27,4 73,5 122,4

Accessori inclusi: Segnaposto in gomma, fascetta fermacavo - Accessories included: Rubber placeholder, cable clip

* necessario circuito di protezione esterno per carico induttivo (valvola, relè, ecc...) - External protective circuit for inductive load (valve, contactor, etc...) necessary.

REED: nessuna funzione LED in caso di inversione di polarità nel funzionamento DC. - No LED function in case of polarity reversal in DC operation.

CONTATTO REED (2 FILI)

36.SEN06

36.SEN06.L6

REED CONTACT (2 WIRES)

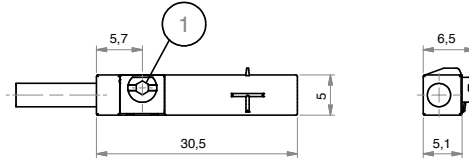

1= ECCENTRICO DI FISSAGGIO - FASTENING CLAMP

CABLAGGIO - WIRING

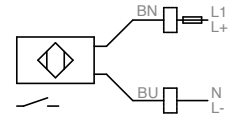

BN= MARRONE - BROWN
BU= BLU - BLUE

CONTATTO REED (CONNETTORE M8)

36.SEN07

REED CONTACT (M8 CONNECTOR)

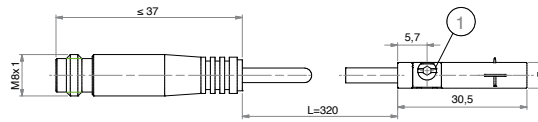

1= ECCENTRICO DI FISSAGGIO - FASTENING CLAMP

CABLAGGIO - WIRING

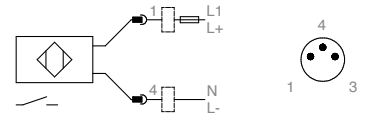

BN= MARRONE - BROWN
BU= BLU - BLUE

CONTATTO PNP (CONNETTORE M8)

36.SEN08

PNP CONTACT (M8 CONNECTOR)

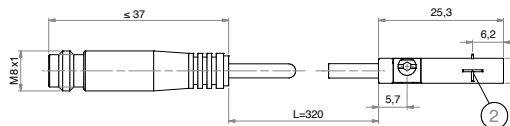

1= ECCENTRICO DI FISSAGGIO FASTENING CLAMP
2= SUPERFICIE ATTIVA SENSING FACE

CABLAGGIO - WIRING

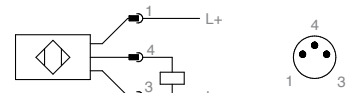

BN= MARRONE - BROWN
BU= BLU - BLUE

CONTATTO PNP (3 FILI)

36.SEN09

36.SEN09.L6

36.SEN09.L10

PNP CONTACT (3 WIRES)

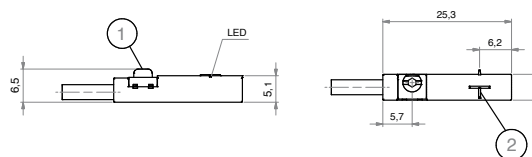

1= ECCENTRICO DI FISSAGGIO - FASTENING CLAMP
2= SUPERFICIE ATTIVA - SENSING FACE

CABLAGGIO - WIRING

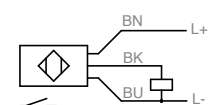

BK= NERO - BLACK
BN= MARRONE - BROWN
BU= BLU - BLUE

CAVO PROLUNGA (CONNETTORE M8)

EXTENSION CABLE (M8 CONNECTOR)

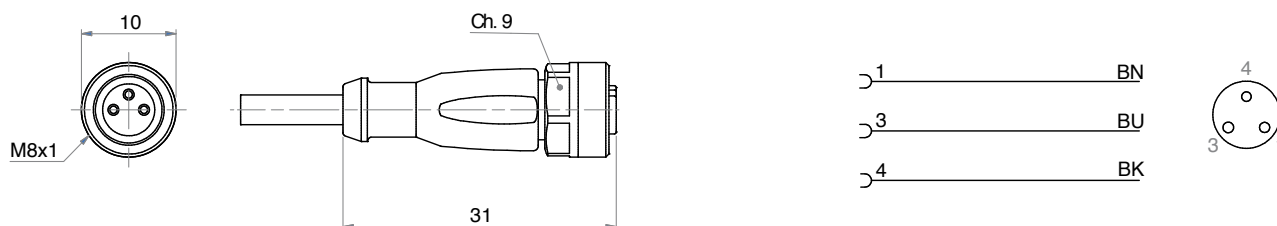
ADATTATORE PER TIRANTE

SENSOR MOUNTING FOR TIE ROD

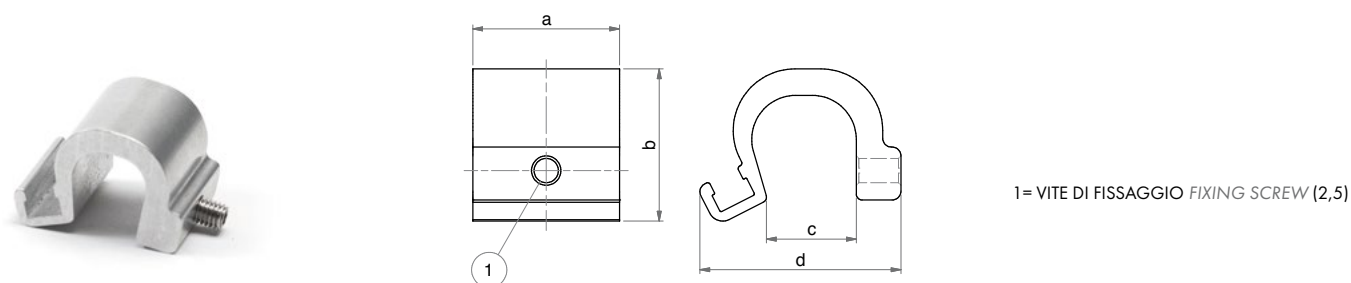
DIMENSIONI - DIMENSIONS

COD.	36.TIR07	36.TIR11	36.TIR15	36.TIR20
Gamma di morsetti - Clamping range [mm]	5÷7	5÷11	9÷15	14÷20
a	25	25	25	25
b	21,6	22,8	25,9	31,1
c	7,5	11,3	15,3	20,3
d	25,4	30,2	34,2	39,6
Materiali involucro - Housing materials	alluminio - aluminium; vite-screw: inox-stainless steel			

SENSORI MAGNETICI ATEX
ATEX MAGNETIC SENSORS

CARATTERISTICHE - CHARACTERISTICS		36.SEN32A.L6	36.SEN33A
TIPO - TYPE		ELETTRONICO - ELECTRONIC	ELETTRONICO - ELECTRONIC
Modello elettrico - Electrical design		DC PNP	DC PNP
Funzione dell'uscita - Output		NO	NO
Tensione di esercizio - Operating voltage	[V]	10...30 DC	10...30 DC
Capacità di corrente - Current rating	[mA]	100	100
Sensibilità di reazione - Magnetic sensitivity	[mT]	2	2,8
Velocità di passaggio - Travel speed	[m/s]	> 10	> 10
Protezione da cortocircuito - Short-circuit proof		si - yes	si - yes
Protetto da inversione di polarità - Reverse polarity protection		si - yes	si - yes
Resistente a sovraccarico - Overload protection		si - yes	si - yes
Caduta di tensione - Voltage drop	[V]	< 2,5	< 2,5
Isteresi - Hysteresis		1	< 1,5
Riproducibilità - Repeatability	[mm]	< 0,2	< 0,2
Corrente assorbita - Current consumption	[mA]	< 10	< 10
Ritardo alla disponibilità - Power-on delay time	[ms]	< 30	< 30
Frequenza di commutazione - Switching frequency	[Hz]	6.000	10.000
Temperatura ambiente - Ambient temperature	[°C]	-20...60	-25...60
Grado/Classe di protezione - Protection		IP 65/IP 67	IP 65/IP 67
Contrassegno - Marking of the unit		II 3D Ex tc IIIC T125°C Dc X II 3G Ex nA IIC T4 Gc X	II 3D Ex tc IIIC T125°C Dc X
Materiale involucro - Housing material		PA (poliammide-polyamide)	PA (poliammide-polyamide)
Materiale eccentrico di fissaggio - Fastening clamp		inox - stainless steel	inox - stainless steel
Indicazione della funzione Stato di commutazione Function display Switching status	LED	giallo - yellow	giallo - yellow
Collegamento - Connection		cavo PVC - PVC cable 3x0,14 mm ²	cavo PVC - PVC cable connettore M12 - M12 connector
Lunghezza cavo - Cable length		6 m	0,3 m
Peso - Weight	[g]	103,3	52,4

Accessori inclusi - Accessories included: Segnaposto in gomma, fascetta fermacavo - Rubber placeholder, cable clip



36.SEN32A.L6

SERIE

H
CONTATTO PNP (3 FILI)
PNP CONTACT (3 WIRES)

1= ECCENTRICO DI FISSAGGIO - FASTENING CLAMP

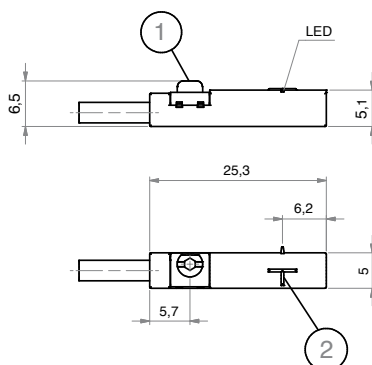
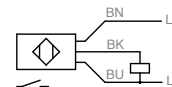
2= SUPERFICIE ATTIVA - SENSING FACE

CABLAGGIO - WIRING

BK= NERO - BLACK

BN= MARRONE - BROWN

BU= BLU - BLUE

CONTATTO PNP (CONNETTORE M12)
PNP CONTACT (M12 CONNECTOR)

1= ECCENTRICO DI FISSAGGIO - FASTENING CLAMP

2= SUPERFICIE ATTIVA - SENSING FACE

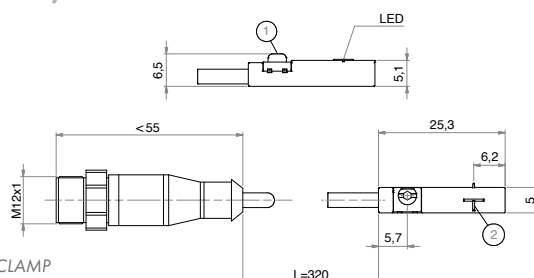
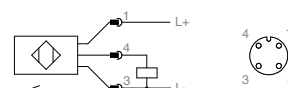
36.SEN33A
CABLAGGIO - WIRING

BK= NERO - BLACK

BN= MARRONE - BROWN

BU= BLU - BLUE

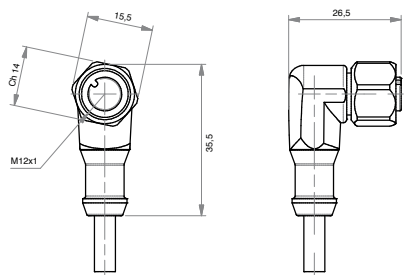
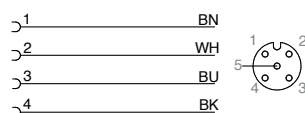
CAVO PROLUNGA (CONNETTORE M12)
EXTENSION CABLE (M12 CONNECTOR)

CABLAGGIO - WIRING

BK= NERO - BLACK

BN= MARRONE - BROWN

BU= BLU - BLUE

WH= BIANCO - WHITE

DIMENSIONI - DIMENSIONS
36.CAV5A.M12
36.CAV10A.M12

DIMENSIONI - DIMENSIONS		36.CAV5A.M12	36.CAV10A.M12
Modello elettrico - Electrical design		AC/DC	AC/DC
Tensione di esercizio - Operating voltage	[V]	60 AC / 60 DC	60 AC / 60 DC
Capacità di corrente - Current rating	[A]	2	2
Modello - Design		ad angolo - angled	ad angolo - angled
Temperatura ambiente - Ambient temperature	[°C]	-20...60	-20...60
Grado/Classe di protezione - Protection		IP67/IP68 - IP69K fuori dalla zona esplosiva - outside hazardous areas	
Contrassegno - Marking of the unit			
Materiale corpo - Body material: Involucro - Housing		TPU arancione - orange TPU	TPU arancione - orange TPU
Guarnizione - Sealing		viton	viton
Materiale dado - Nut material		inox - stainless steel (1.4404 / 316L)	inox - stainless steel (1.4404 / 316L)
Coppia di serraggio per nodo nocciolo	[Nm]	0,2...1,5	0,2...1,5
Collegamento - Connection		cavo PUR - PUR cable / 5 m; 4 x 0,34 mm ² (42 x Ø 0,1 mm); Ø 4,9 mm; senza alogeno - alogen free	cavo PUR - PUR cable / 10 m; 4 x 0,34 mm ² (42 x Ø 0,1 mm); Ø 4,9 mm; senza alogeno - alogen free
Colore della guaina - Sheath colour		nero - black	nero - black